

Holley Carburetor Model 4150/4150C Instruction Sheet 199R8378

TYPICAL VIEW

The exploded view shown is typical of the model carburetor this kit will service. The view may differ slightly from the actual carburetor being renewed.

This kit may contain more parts than are actually required to service a given carburetor. When similar gaskets or parts are included in the kit, compare with the original parts.

DISASSEMBLY:

Rest the carburetor on a repair stand to avoid damage to the throttle plates during the renew procedures. Use the exploded view as a guide, and follow the numerical sequence in general to disassemble the unit far enough to permit cleaning and inspection. Do not remove the throttle plates or shaft. Idle limiter: turn the idle limiter caps to its leanest (clockwise) position and remove the cap. Observe and record the initial position of the needle slot. Turn the idle needs until lightly seated, recording the number of turns required to seat the needles. This procedure is necessary to reinstall the idle needles after renewing.

Use care not to damage the idle adjusting needles when removing the idle limiter caps.

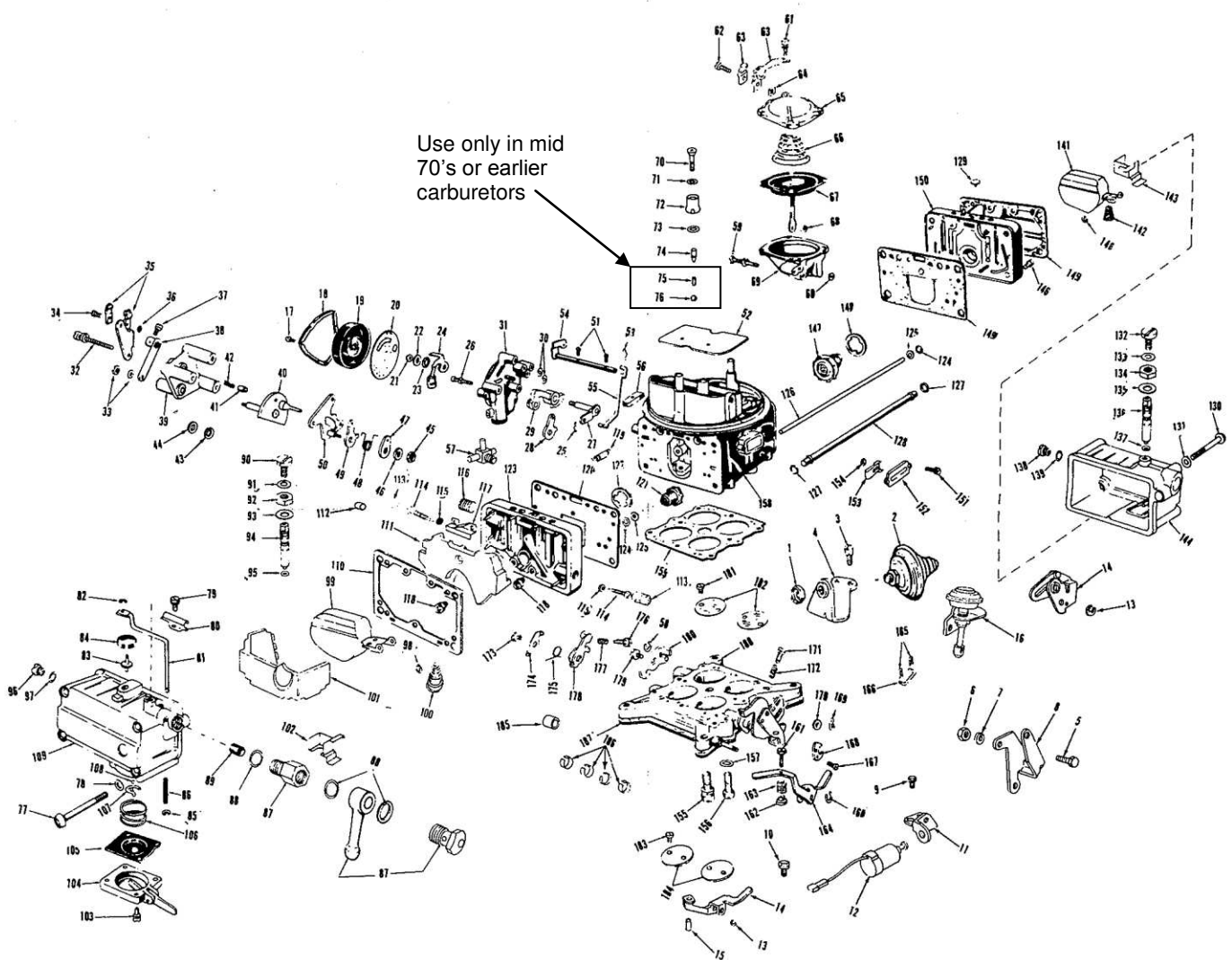

Ref. No.	Desc	Ref. No.	Desc	Ref. No.	Desc
1	Dashpot nut	64	Clamp screw nut	127	Fuel line tube o-ring seal
2	Dashpot assembly	65	Sec. diaph. cover	128	Fuel line tube
3	Dashpot bracket screw	66	Sec. diaph. spring	129	Sec. bow l vent valve
4	Dashpot bracket	67	Sec. diaph. & link assy	130	Sec. fuel bow l screw
5	Throttle lever extension screw	68	Sec. diaph. housing check ball	131	Sec. fuel bow l screw gasket
6	Throttle lever extension nut	69	Sec. diaph. housing	132	Sec. fuel valve seat lock screw
7	Throttle lever extension nut	70	Pump disch. nozzle screw	133	Sec. fuel valve seat lock screw gasket
8	Throttle lever extension	71	Pump disch. nozzle screw gasket	134	Sec. fuel valve seat adj. nut
9	Solenoid bracket screw	72	Pump disch. nozzle	135	Fuel valve seat adj. nut gasket
10	Solenoid bracket screw	73	Pump disch. nozzle gasket	136	Sec. fuel inlet valve & seat assy
11	Solenoid bracket	74	Pump disch. needle valve	137	Fuel valve seat o-ring seal
12	Solenoid assembly	75	Pump check ball w weight	138	Sec. fuel level check plug
13	Cam follow er retainer	76	Pump disch. nozzle check ball	139	Fuel level check plug gasket
14	Cam follow er lever	77	Primary fuel bow l screw	140	Float retainer
15	Pump oper. lever screw sleeve	78	Primary fuel bow l screw gasket	141	Sec. float assy
16	Modulator assembly	79	Air vent clamp screw	142	Sec. float spring
17	Therm. housing clamp screw	80	Air vent rod clamp	143	Sec. baffle plate
18	Therm. housing clamp	81	Air vent rod	144	Sec. fuel bow l assy
19	Thermostat housing assembly	82	Air vent valve retainer	145	Sec. fuel bow l gasket
20	Thermostat housing gasket	83	Air vent valve	146	Sec. metering jet
21	Choke therm. shaft nut	84	Air vent cap	147	Sec. pow er valve assy
22	Shaft nut lockw asher	85	Air vent rod spring retainer	148	Sec. pow er valve gasket
23	Therm. lever spacer	86	Air vent rod spring	149	Sec. metering body gasket
24	Therm. lever , link & piston assy	87	Fuel inlet fitting	150	Sec. metering body assy
25	Choke rod retainer	88	Fuel inlet fitting gasket	151	H.I.C. cover screw
26	Choke housing screw	89	Fuel inlet filter	152	H.I.C. cover
27	Choke housing lever & shaft assy	90	Pri. fuel valve seat lock screw	153	Hot idle compensator assy
28	Choke therm. lever	91	Fuel valve seat lock screw gasket	154	H.I.C. seal
29	Fast idle cam assy	92	Fuel valve seat adj. nut	155	Throttle body screw & lockw asher
30	Choke housing gasket	93	Fuel vlave adj. nut gasket	156	Throttle body screw
31	Choke housing assembly	94	Pri. fuel inlet & valve seat assy	157	Throttle body screw gasket
32	Fast idle cam plate screw	95	Fuel valve seat o-ring seal	158	Main body assy
33	Choke control lever nut & lockw asher	96	Fuel level check plug	159	Throttle body gasket
34	Wire bracket clamp screw	97	Fuel level check plug gasket	160	Pump oper. lever retainer
35	Choke control wire bracket clamp	98	Float retainer	161	Pump lever adj. screw
36	Wire bracket clamp screw nut	99	Primary float assy	162	Pump lever adj. screw fitting
37	Choke lever assy sw ivel screw	100	Primary float spring	163	Pump lever adj. screw spring
38	Choke lever & sw ivel assy	101	Primary fuel bow l filler	164	Pump lever
39	Fast idle cam plate	102	Primary baffle plate	165	Throttle connector rod cotter pin
40	Fast idle cam & shaft assy	103	Pump diaph. cover screw & lockw asher	166	Throttle connector rod
41	Fast idle cam plunger	104	Pri. pump diaph. cover assy	167	Pump cam lock screw
42	Fast idle cam plunger spring	105	Primary pump diaph. assy	168	Pump cam
43	Choke oper. lever spring w asher	106	Pri. diaph. return spring	169	Throttle connector pin retainer
44	Choke oper. lever w asher	107	Pri. check ball retainer	170	Throttle connector pin w asher
45	Back up plate stud nut	108	Pri. check ball or check valve	171	Throttle stop screw
46	Stud nut lockw asher	109	Pri. fuel bow l assy	172	Throttle stop screw spring
47	Choke spring w asher	110	Pri. fuel bow l gasket	173	Fast idle cam lever screw & lockw asher
48	Choke spring	111	Pri. metering body filler	174	Fast idle cam pick up lever
49	Choke rod & lever bushing assy	112	Vacuum tube plug	175	Fast idle cam lever spring
50	Back up plate & stud assy	113	Idle limiter cap	176	Fast idle cam lever adj. screw
51	Choke plate screw	114	Idle adj. needle	177	Fast idle cam lever adj. screw spring
52	Choke plate	115	Idle adj. needle seal	178	Fast idle cam lever
53	Choke rod retainer	116	Spark hole plug	179	Sec. diaph. lever assy screw
54	Choke lever & shaft assy	117	Metering body vent baffle	180	Sec. diaph. lever assy
55	Choke rod	118	Primary metering jet	181	Sec. throttle plate screw
56	Choke rod seal	119	Tube & o-ring assy	182	Sec. throttle plate
57	Four-w ay hose connector	120	Pri. metering body gasket	183	Pri. throttle plate screw
58	Sec. diaph. link retainer	121	Pri. pow er valve assy	184	Pri. throttle plate
59	Sec. diaph. housing screw	122	Pri. pow er valve gasket	185	Pri. throttle shaft bearing (solid)
60	Sec. diaph. housing gasket	123	Pri. metering body assy	186	Throttle shaft bearing (ribbon) pri. & sec.
61	Sec. diaph. cover screw	124	Balance tube w asher	187	Flange gasket
62	Wire bracket & clamp screw	125	Balance tube o-ring seal	188	Throttle body assy
63	Wire bracket clamp	126	Balance tube		

CLEANING:

Cleaning must be done with the carburetor disassembled. Soak parts long enough to soften and remove all foreign material. Use a carburetor solvent, lacquer thinner, or denatured alcohol. Make certain the throttle body is free of all hard carbon deposits. Wash off in suitable solvent. Blow out all passages in castings with compressed air and check carefully to insure thorough cleaning of obscure areas.

CAUTION: Do not soak parts containing rubber or plastic material. Serious damage could result.

NOTE: Some fuel bowls have internal o-ring seals which are not removable, but can be damaged by prolonged exposure to some carburetor cleaning solvents.

REASSEMBLY:

Reassemble in reverse order to disassembly. Note special instructions and follow outline in making adjustments.

Manually operate the throttle lever and choke mechanism, checking for binding or malfunction. Any binding or interference could cause throttle to stick during operation and result in loss of carburetor throttle control (or uncontrolled engine speed).

Check carburetor to be sure there are no leaks. Flooding could cause a fire.

SPECIAL INSTRUCTIONS:

IDLE ADJUSTING NEEDLES – Tapered portion of needle must be straight and smooth. If grooved or ridged, a new needle should be installed.

PUMP INLET CHECK VALVE – Lubricate tip of new valve and insert in center hole in pump cavity. Pull thru from fuel bowl side until seated.

CHOKE PLATE SCREW – Choke plate screws are staked to prevent loosening. To avoid breaking or stripping the threads in the choke shaft, lightly file off the staking. Choke plate screws should be restaked after tightening to prevent loosening.

THROTTLE BODY – Do not remove throttle shaft or plates. If throttle plates are nicked or damaged, it will be necessary to replace the throttle body.

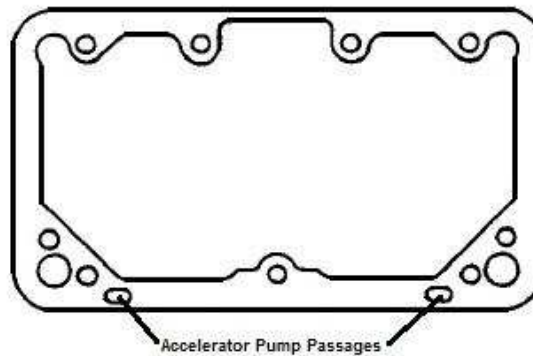

The primary fuel bowl gasket must be installed with the accelerator pump passage on the right side of the main jets. Fuel bowl screws must be torqued to 40 in./lbs.

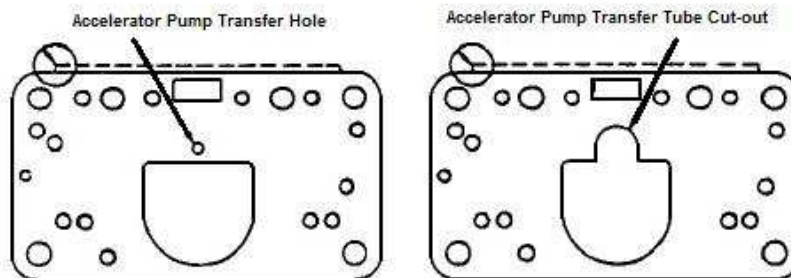

METERING BODY GASKETS

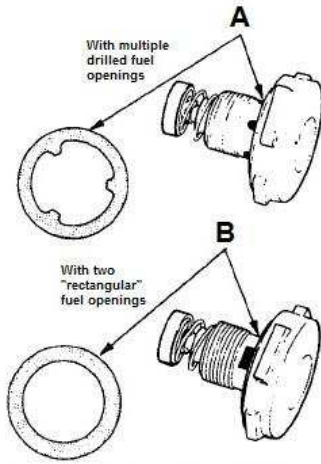

NOTE: Proper power valve gasket must be used as shown, use of improper gasket will result in fuel leakage around power valve.
 Power valve (A): Torque to 40-50 in./lbs.
 Power valve (B): Torque to 40-50 in./lbs.

FIG. 1 - POWER VALVE INSTALLATION

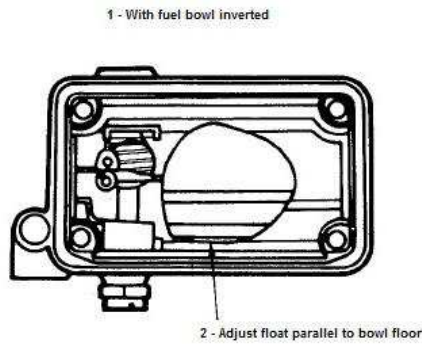

External Adjustable Type

FIG. 2 - DRY FLOAT SETTING

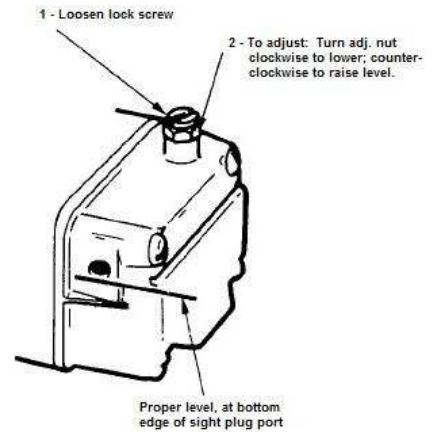

With car on level surface and engine running

FIG. 3 - WET LEVEL ADJUSTMENT

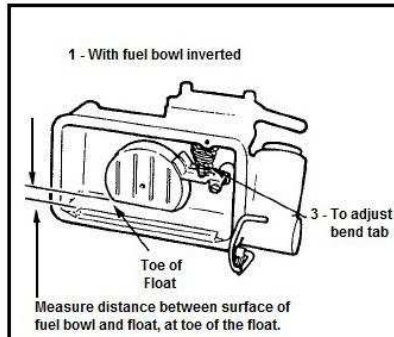

Non-Adjustable Type

FIG. 4 - DRY FLOAT SETTING

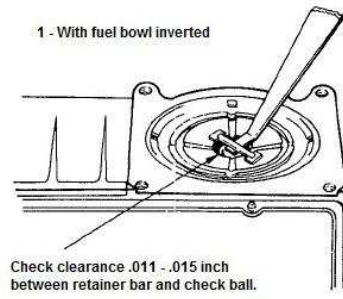

FIG. 5 - PUMP INTAKE CHECK BALL ADJ.

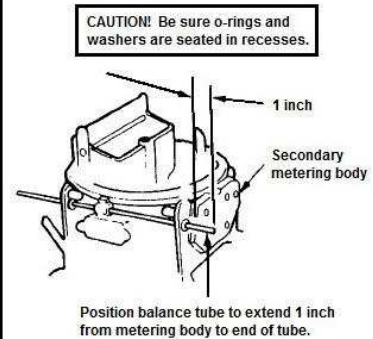

FIG. 6 - BALANCE TUBE ADJUSTMENT

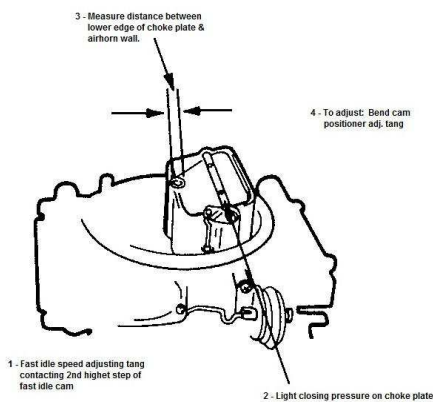

FIG. 7 - CAM INDEX ADJUSTMENT

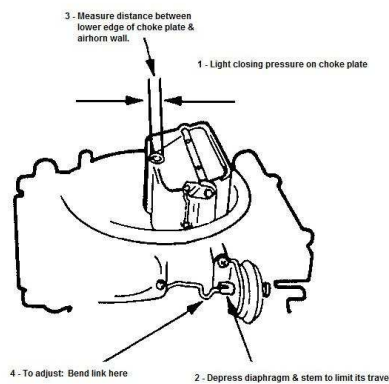

FIG. 8 - VACUUM KICK ADJUSTMENT

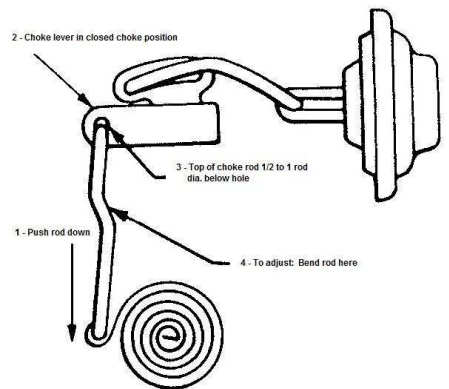

FIG. 9 - CHOKE ROD ADJUSTMENT

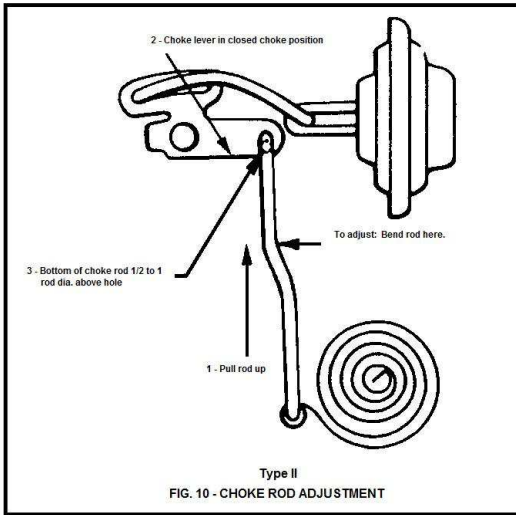

FIG. 10 - CHOKE ROD ADJUSTMENT

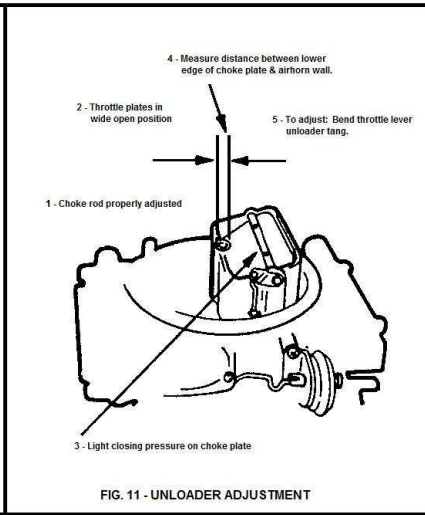

FIG. 11 - UNLOADER ADJUSTMENT

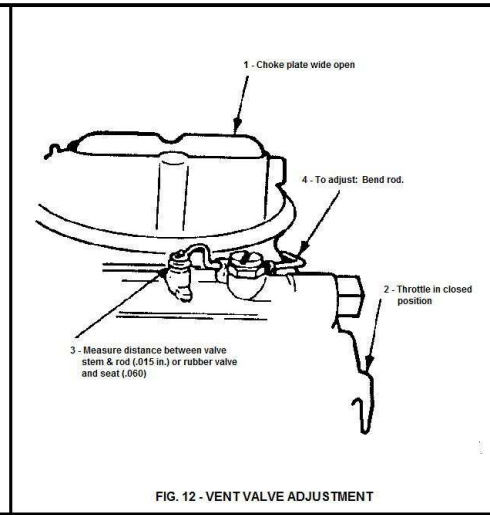

FIG. 12 - VENT VALVE ADJUSTMENT

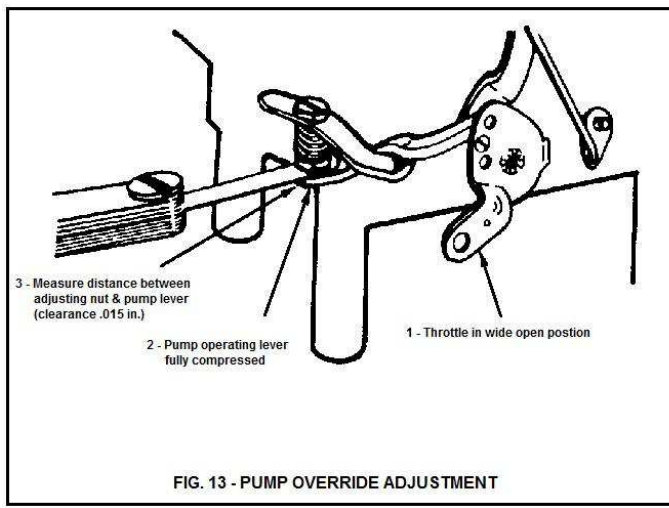

FIG. 13 - PUMP OVERRIDE ADJUSTMENT

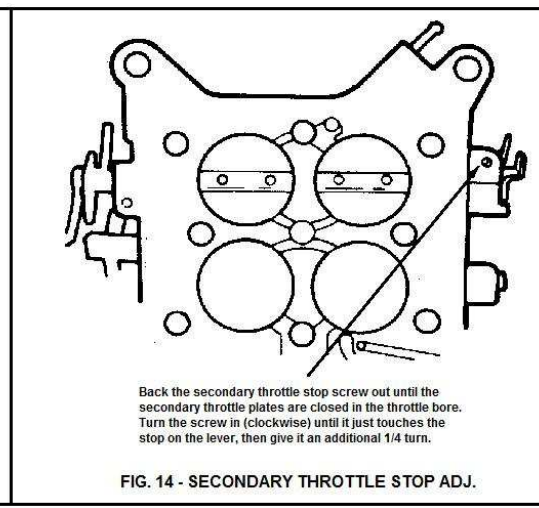

FIG. 14 - SECONDARY THROTTLE STOP ADJ.

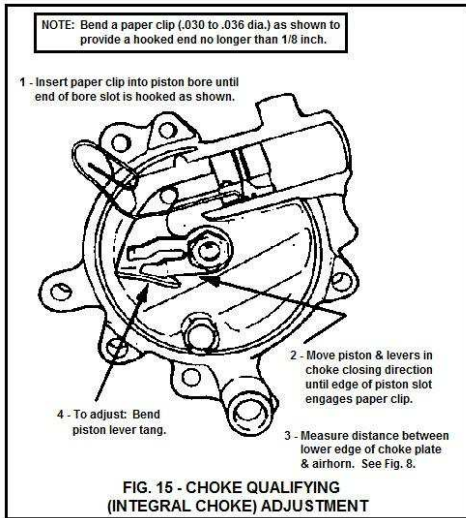

FIG. 15 - CHOKE QUALIFYING (INTEGRAL CHOKE) ADJUSTMENT

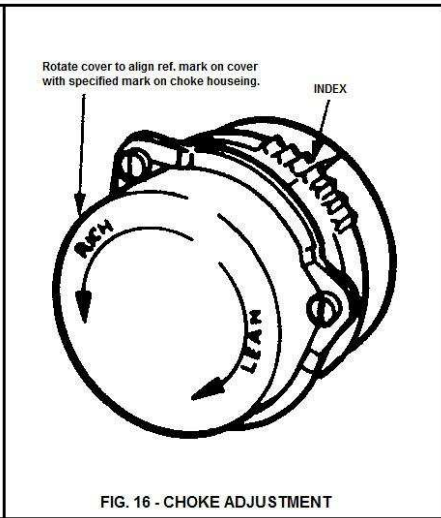

FIG. 16 - CHOKE ADJUSTMENT

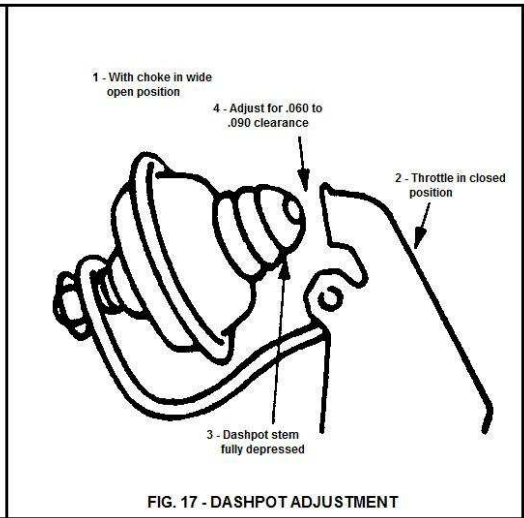

FIG. 17 - DASHPOT ADJUSTMENT

Example: Power Valve Assembly

125 - 65

65 which designates the stamped number, also identifies the opening point of the power valve (i.e., 6.5" vacuum).

Code Letter A thru M for Month -
omitting Letter I - Use J for Sept.

First Digit of Stamped
Number Identification

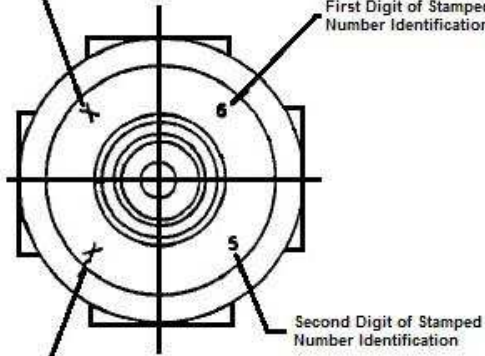

Second Digit of Stamped
Number Identification

Code Number 0 thru 9 for Year

POWER VALVE IDENTIFICATION

**Holley Technical Support
1801 Russellville Road
Bowling Green, KY 42101**

**Phone: 270-781-9741
Fax: 270-781-9772
www.holley.com**