



INTAKE SYSTEMS FOR VEHICLES LISTED ARE 50 STATE LEGAL. SEE KNFILTERS.COM FOR CARB STATUS ON EACH PART FOR A SPECIFIC VEHICLE.

INSTALLATION INSTRUCTIONS

57-3052
CHEVROLET
2005 Corvette
V8-6.0L

TOOLS NEEDED:

- Flat Blade Screwdriver
- 10mm Wrench

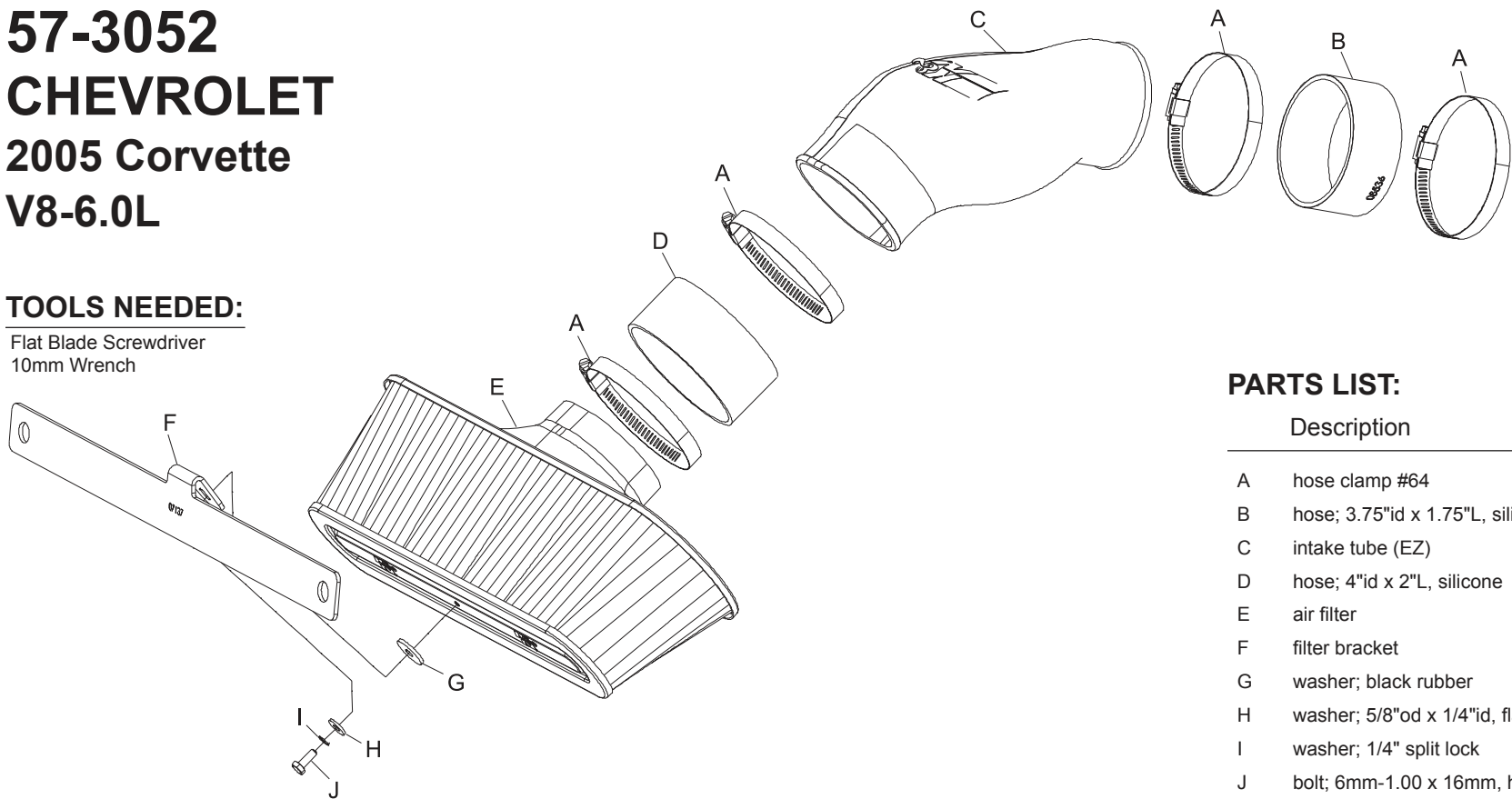

PARTS LIST:

	Description	Qty.	Part #
A	hose clamp #64	4	08645
B	hose; 3.75" id x 1.75" L, silicone	1	08536
C	intake tube (EZ)	1	087169
D	hose; 4" id x 2" L, silicone	1	08625
E	air filter	1	RP-5135
F	filter bracket	1	010111
G	washer; black rubber	1	21685
H	washer; 5/8" od x 1/4" id, flat	1	08275
I	washer; 1/4" split lock	1	08198
J	bolt; 6mm-1.00 x 16mm, hex	1	07703

NOTE: FAILURE TO FOLLOW INSTALLATION INSTRUCTIONS AND NOT USING THE PROVIDED HARDWARE MAY DAMAGE THE INTAKE TUBE, THROTTLE BODY AND ENGINE.

TO START:

1. Turn off the ignition and disconnect the negative battery cable.

NOTE: Disconnecting the negative battery cable erases pre-programmed electronic memories. Write down all memory settings before disconnecting the negative battery cable. Some radios will require an anti-theft code to be entered after the battery is reconnected. The anti-theft code is typically supplied with your owner's manual. In the event your vehicles anti-theft code cannot be recovered, contact an authorized dealership to obtain your vehicles anti-theft code.

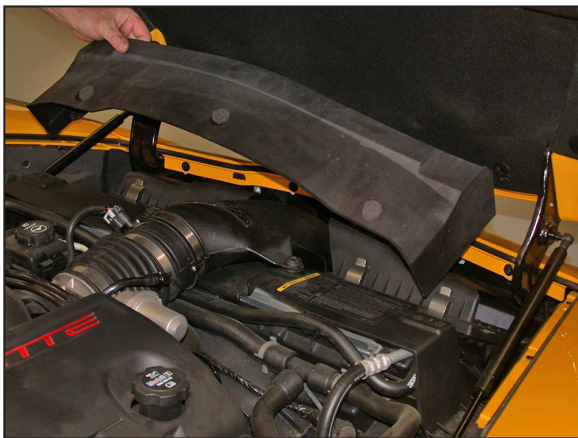

2. Unsnap the ends and then remove the air filter cover as shown.



3. Loosen the hose clamp which secures the stock intake tube to the mass air sensor, then pull up to release the center locking pins in the intake tube mounting fasteners shown.



4. Pull up on the complete intake system to disconnect it from the air box mounting pins and then remove it from the vehicle as shown. **NOTE: K&N Engineering, Inc., recommends that customers do not discard factory air intake.**

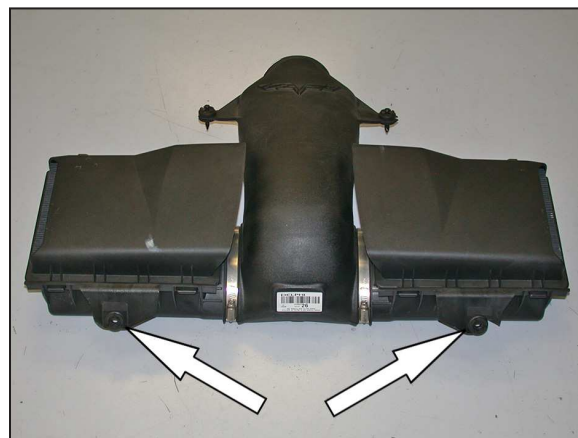

5. Remove the two rubber mounting grommets shown air box as shown.



6. Install the two rubber mounting grommets from step #5 into the filter-mounting brackets as shown.



7. Install the silicone hose (08625) onto the air filter as shown and secure with the provided hose clamps.



8. Install the K&N® intake tube onto the air filter as shown and secure with the provided hose clamp.



9. Install the silicone hose (08536) onto the K&N® intake tube and secure with the provided hose clamps.



10. Install the filter-mounting bracket onto the air filter as shown and secure with the provided hardware.



11. Install the intake kit assembly into the vehicle as shown.



12. Snap the filter-mounting bracket onto the filter as shown and secure with the provided hardware.



13. Install the intake kit onto the mass air sensor secure with the provided hose clamp.



14. Reconnect the vehicle's negative battery cable. Double check to make sure everything is tight and properly positioned before starting the vehicle.

15. The C.A.R.B. exemption sticker, (attached), must be visible under the hood so that an emissions inspector can see it when the vehicle is required to be tested for emissions. California requires testing every two years, other states may vary.

16. It will be necessary for all K&N® high flow intake systems to be checked periodically for realignment, clearance and tightening of all connections. Failure to follow the above instructions or proper maintenance may void warranty.

ROAD TESTING:

1. Start the engine with the transmission in neutral or park, and the parking brake engaged. Listen for air leaks or odd noises. For air leaks secure hoses and connections. For odd noises, find cause and repair before proceeding. This kit will function identically to the factory system except for being louder and much more responsive.

2. Test drive the vehicle. Listen for odd noises or rattles and fix as necessary.

3. If road test is fine, you can now enjoy the added power and performance from your kit.

4. K&N Engineering, Inc., requires cleaning the intake system's air filter element every 100,000 miles. When used in dusty or off-road environments, our filters will require cleaning more often. We recommend that you visually inspect your filter once every 25,000 miles to determine if the screen is still visible. When the screen is no longer visible some place on the filter element, it is time to clean it. To clean and re-oil, purchase our filter Recharger® service kit, part number 99-5050 or 99-5000 and follow the easy instructions.

INTAKE SYSTEMS FOR VEHICLES LISTED ARE 50 STATE LEGAL. SEE KNFILTERS.COM FOR CARB STATUS ON EACH PART FOR A SPECIFIC VEHICLE.