



DODGE RAM 1500 4WD 2" FRONT & 1.5" REAR COIL SPRING LIFT KIT INSTALLATION INSTRUCTIONS 2009-2014 KIT# DL229PA

⚠ WARNING

Many states and municipalities have laws restricting bumper heights and vehicle lifts. Consult state and local laws to determine if the changes you intend to make to the vehicle comply with the law.

⚠ WARNING

The installation of larger tires may reduce the effectiveness of the braking system.

⚠ WARNING

Always wear eye protection when operating power tools.

⚠ WARNING

Before you install this kit, block the vehicle tires to prevent the vehicle from rolling.

⚠ WARNING

DO NOT combine suspension, body, or other lift devices. Use of vehicle with combined lifts may result in unsafe and/or unexpected handling characteristics.

NOTE

Lift height may vary depending on vehicle configuration, engine size, additional accessories, the factory suspension package, and vehicle's condition.

⚠ WARNING

Installation of a Performance Automotive Group suspension lift kit will change the vehicle's center of gravity and handling characteristics both on- and off-road. You must drive the vehicle safely! Extreme care must be taken to prevent vehicle rollover or loss of control, which could result in serious injury or death. Avoid sudden sharp turns or abrupt maneuvers and always make sure all vehicle occupants have their seat belts fastened.

⚠ WARNING

Before you install this kit, read and understand all instructions, warnings, cautions, and notes in this instruction sheet and in the vehicle owner's manual.

⚠ CAUTION

Proper installation of this kit requires knowledge of the factory recommended procedures for removal and installation of original equipment components. We recommend that the factory shop manual and any special tools needed to service your vehicle be on hand during the installation. Installation of this kit without proper knowledge of the factory recommended procedures may affect the performance of these components and the safety of the vehicle. We strongly recommend that a certified mechanic familiar with the installation of similar components install this kit.

⚠ WARNING

This kit should only be installed on a vehicle that is in good working condition. Before you install the kit, thoroughly inspect the vehicle for corrosion or deformation of the sheet metal. If the vehicle is suspected to have been in a collision or misused, do not install this kit. Off-road use of your vehicle with this kit installed may increase the stress applied to the factory components. Failure to observe this warning may result in serious personal injury and/or severe damage to your vehicle.

Before Starting Installation

NOTE
Kit parts are prefaced by the word *kit* and appear in **bold** print.

1. Carefully read all warnings and instructions completely before beginning.
2. Verify all parts have been received in this kit by checking the parts list at the end of this document.
3. **Only install this kit on the vehicle for which it is specified.** If anytime during the installation you encounter something different from what is outlined in the instructions, call technical support at (928) 636-3175.
4. Special tools needed:
 - a. Coil spring compressors
 - b. Tie rod puller
5. Park vehicle on a clean, dry, flat, level surface and block tires so vehicle cannot roll in either direction.

NOTE
Adhere to recommendations when replacement fasteners, retainers and keepers are called out in the factory service manual. When re-assembling the vehicle it is recommended by the vehicle manufacturer that certain fasteners are replaced in order to maintain proper retention characteristics. This system may not include all replacement hardware as recommended by the factory service manual. Additional replacement hardware should be obtained prior to installation of this system to meet the requirements of the factory service manual.

Ride Height

1. Measure ride height with the vehicle supporting its own weight on level ground. To settle the suspension, the vehicle should be driven forward at least 10 feet immediately prior to taking these measurements. Ride height is the measurement from the center of the axle straight up (vertical) to the fender lip. Record this measurement for all four wheels.

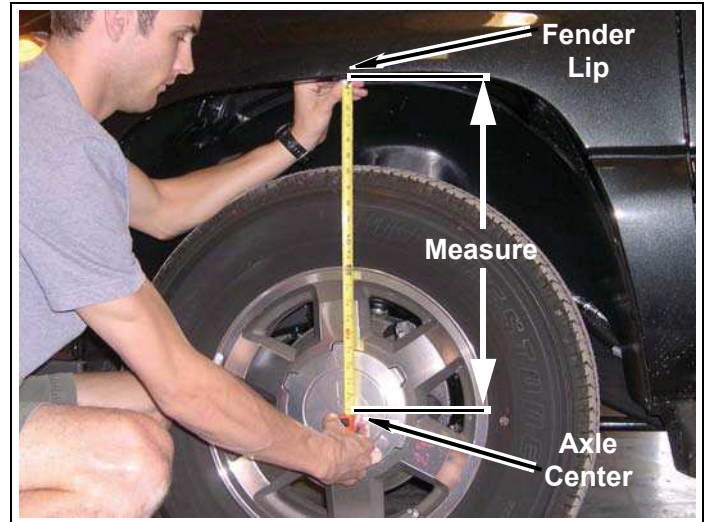

Torque Specifications

1. See factory service manual for torque values when re-using OE fasteners.

<u>Bolt Size</u>	<u>Grade 5 (ft.-lbs.)</u>	<u>Grade 8 (ft.-lbs.)</u>
1/4"-20	10	10
1/4"-28	10	12.5
5/16"-18	17	22.5
5/16"-24	20	25
3/8"-16	30	40
3/8"-24	35	45
7/16"-14	50	65
7/16"-20	55	70
1/2"-13	75	100
1/2"-20	55	70
9/16"-12	105	135
9/16"-18	115	150
5/8"-11	150	195
5/8"-18	160	210
3/4"-16	175	225

Engine Compartment

1. Disconnect both battery cables. Disconnect negative cable first, then positive cable.

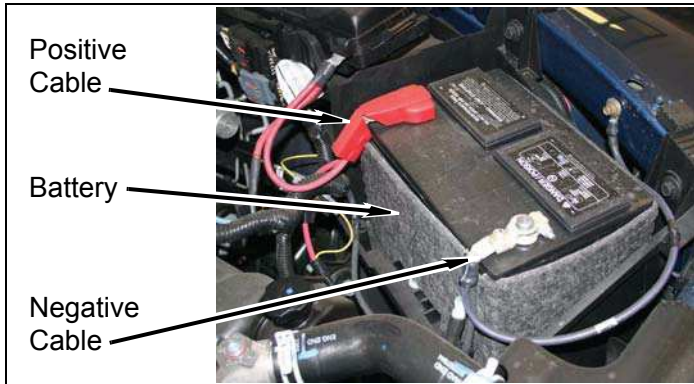

Prepare to Install Front Kit

⚠ WARNING

Compressed coil springs can expand violently causing serious personal injury. Use caution when using coil spring compressors.

1. Loosen, but do not remove, lug nuts on each front wheel.
2. Using a hydraulic floor jack, slowly lift front axle until front tires are 3-5" off ground. Position jack stands under frame. Lower vehicle onto jack stands while maintaining hydraulic jack pressure underneath front of vehicle.

⚠ WARNING

Use extreme caution when lifting vehicle from ground. To prevent serious personal injury, ensure the lifting device is securely placed.

3. Remove lug nuts and front wheels from vehicle.

4. Remove two nuts, two washers, two bushings, and sway bar from driver and passenger sway bar end links.

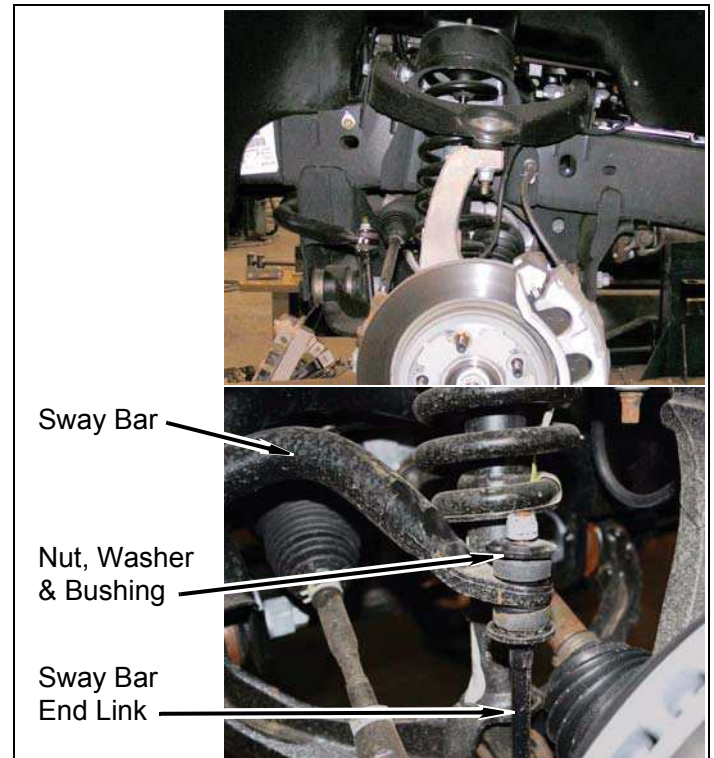

5. Driver coil-over assembly

NOTE

It may be necessary to use a tie rod puller to remove steering tie rod end from steering knuckle.

- a. Remove nut and steering tie rod end from steering knuckle.

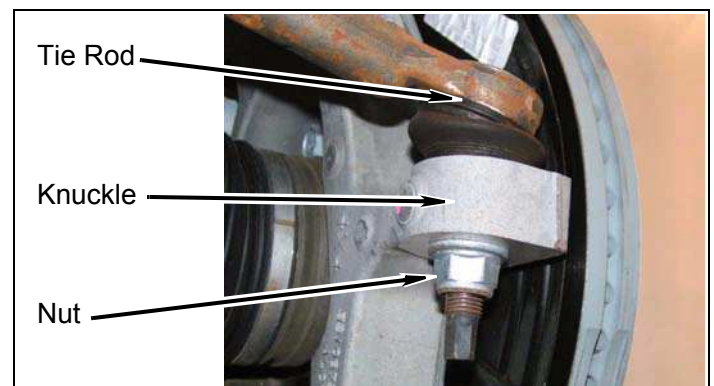

b. Remove nut and upper A-arm from steering knuckle.

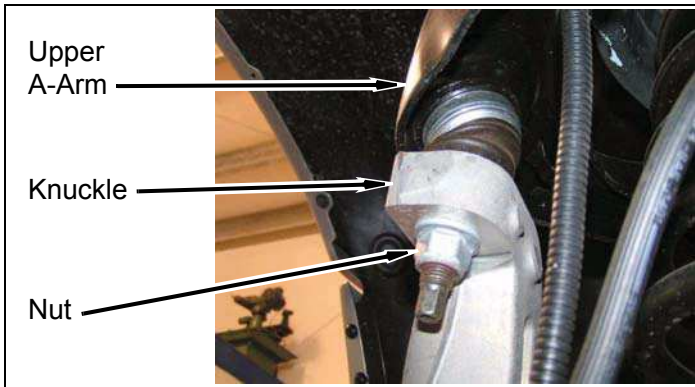

c. Remove nut and bolt from coil-over assembly and lower A-arm.

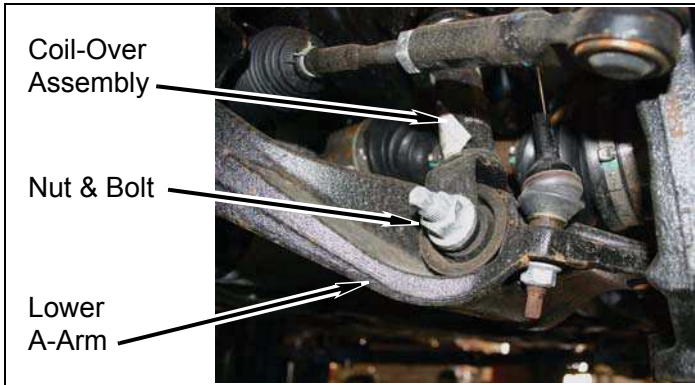

d. Remove three nuts and coil-over assembly from upper perch.

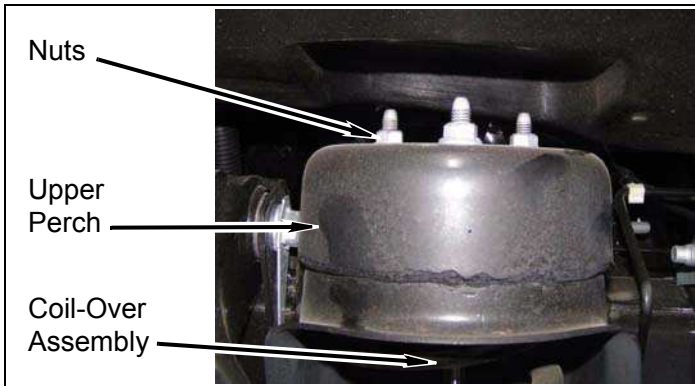

e. Repeat above substeps for passenger coil-over assembly.

Install Front Coil Spacer Kit

1. Coil spacers

⚠ WARNING
Compressed coil springs can expand violently causing serious personal injury. Use caution when using coil spring compressors.

a. Paint upper plate, ramp, coil spring, isolator, and shock with alignment mark for proper re-assembly.

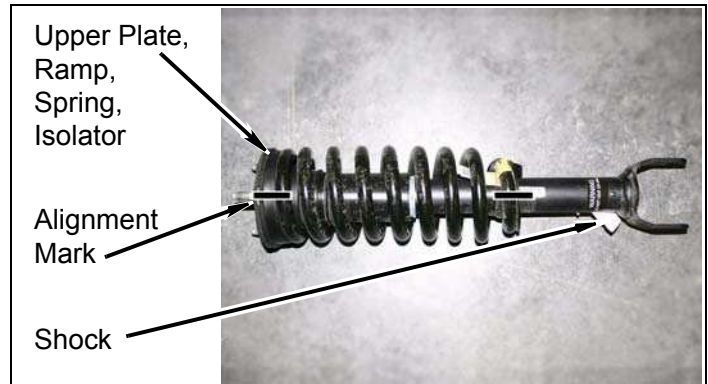

b. Using coil spring compressors, compress coil spring until shock is loose on coil spring.

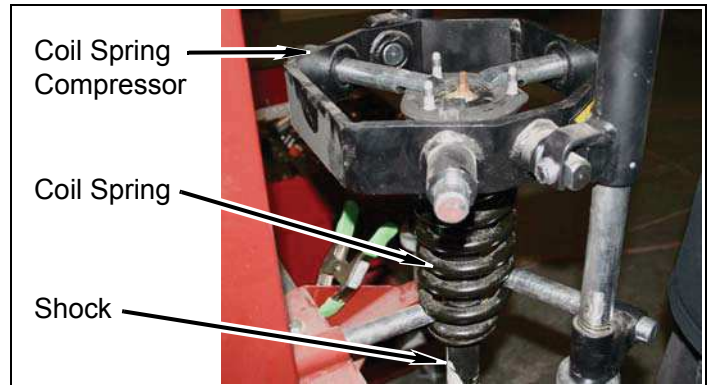

c. Remove nut and shock from coil spring and upper plate.

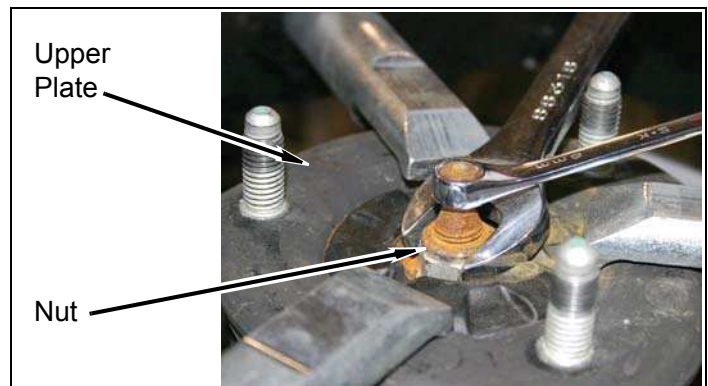

NOTE

When removing shock from upper plate, ensure metal ring is seated on shock rod step.

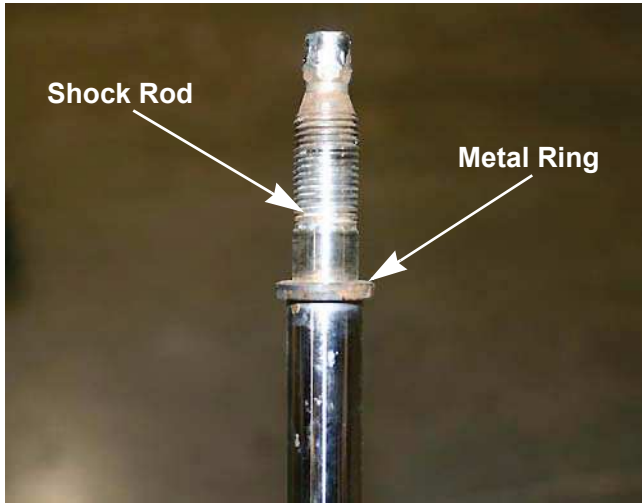

- d. Uncompress coil spring and remove upper plate and isolator from ramp and coil spring.
- e. Install *kit spacer* onto isolator and upper plate.

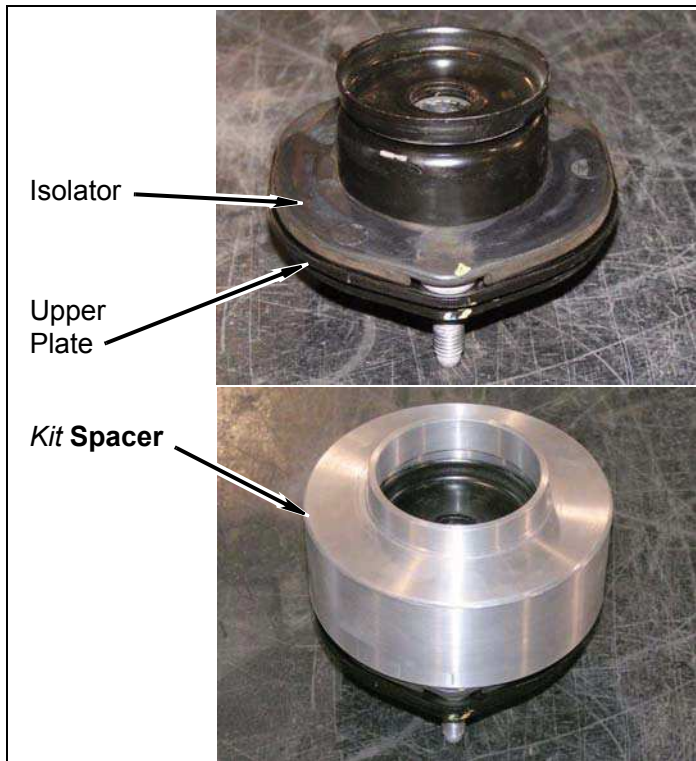

- f. Align previously painted alignment marks and install upper plate, *kit spacer*, and isolator onto ramp and coil spring.

NOTE

When installing shock onto upper plate, ensure metal ring is seated on shock rod step.

- g. Compress coil spring and align previously painted alignment marks and install shock onto upper plate with nut.

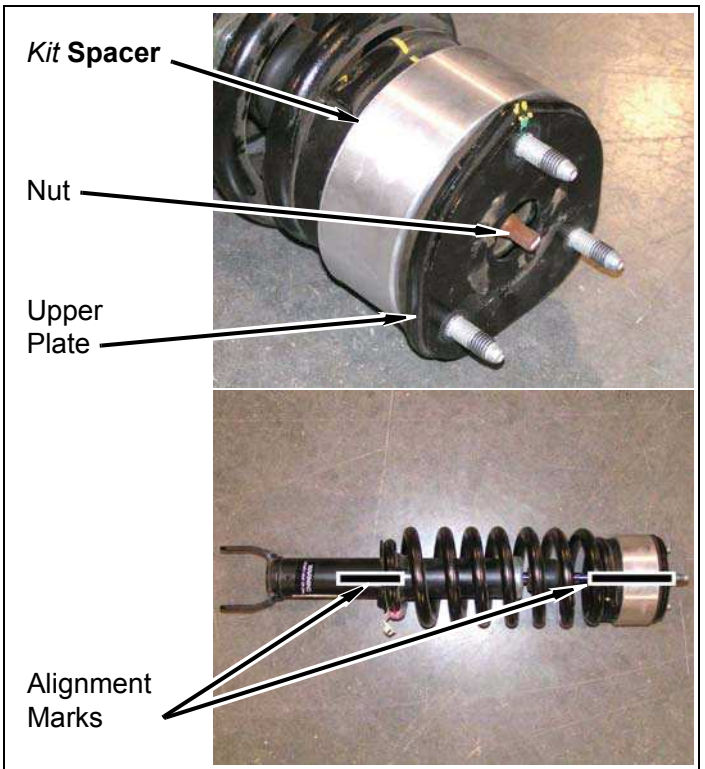

- h. Repeat above substeps for passenger coil spacer.

2. Driver coil-over assembly

- a. Install coil-over assembly onto upper perch with three nuts. DO NOT TIGHTEN.

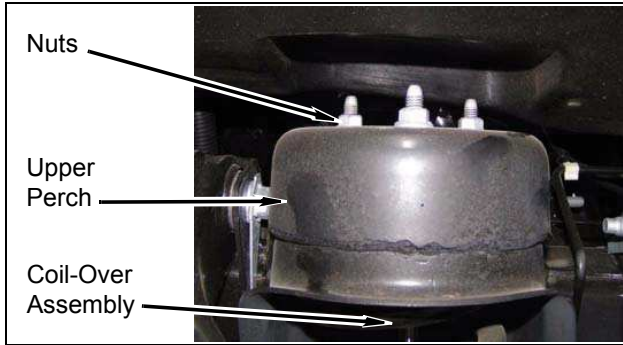

- b. Install coil-over assembly onto lower A-arm with bolt and nut. TORQUE to O.E. specification.

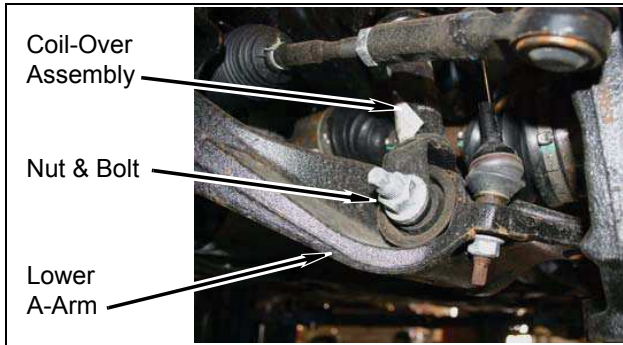

- c. TORQUE three upper perch nuts to O.E. specification.

- d. Install upper A-arm onto steering knuckle with nut. TORQUE to O.E. specification.

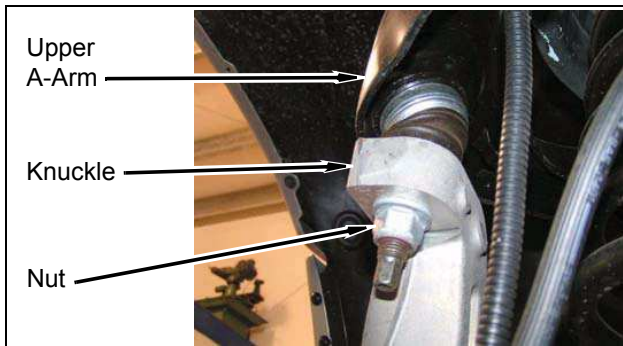

- e. Install steering tie rod end onto steering knuckle with nut. TORQUE to O.E. specification.

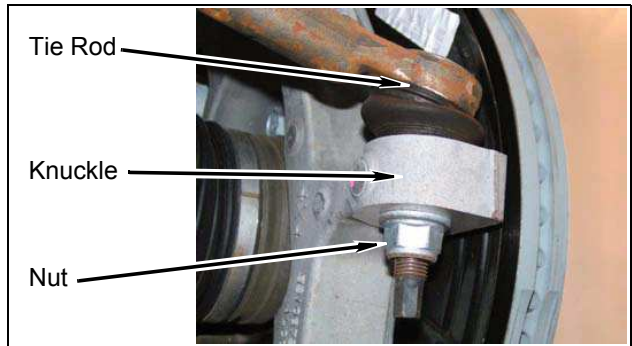

- f. Repeat above substeps for passenger coil-over assembly.

CAUTION

DO NOT OVER COMPRESS sway bar bushings in the following step. Damage may occur to bushings, sway bar, or sway bar end links.

3. Install sway bar onto driver and passenger sway bar end links with two bushings, two washers, and two nuts. TIGHTEN two nuts until bushings are SLIGHTLY COMPRESSED.

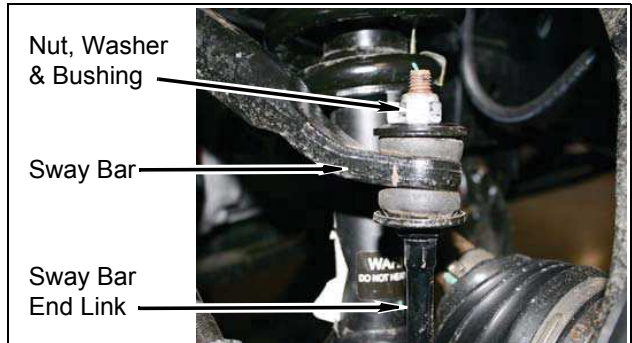

4. Install front wheels onto vehicle with lug nuts. Snug, but DO NOT TIGHTEN.

5. Using hydraulic floor jack, raise front of vehicle and remove jack stands. Slowly lower vehicle onto ground.

6. TORQUE front lug nuts to specification.

Prepare to Install Rear Kit

⚠ WARNING

Compressed coil springs can expand violently causing serious personal injury. Use caution when using coil spring compressors.

1. Loosen, but do not remove, lug nuts on each rear wheel.
2. Using a hydraulic floor jack, slowly lift rear axle until front tires are 3-5" off ground. Position jack stands under frame. Lower vehicle onto jack stands while maintaining hydraulic jack pressure underneath front of vehicle.

⚠ WARNING

Use extreme caution when lifting vehicle from ground. To prevent serious personal injury, ensure the lifting device is securely placed.

3. Remove lug nuts and rear wheels from vehicle.
4. Remove two lower nuts from both rear sway bar end links.

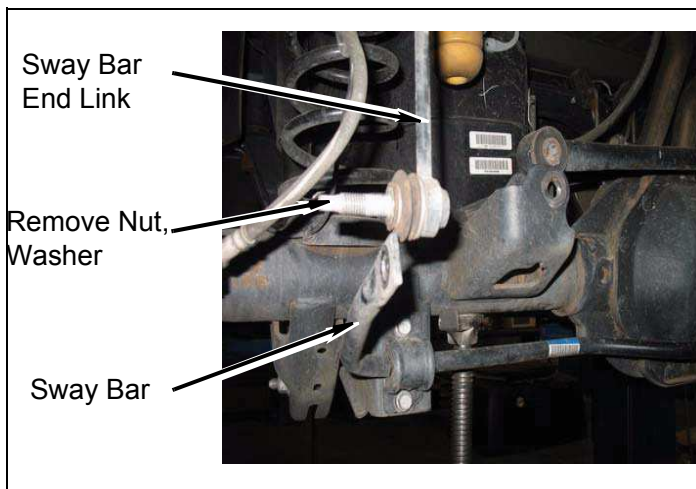

5. Remove two lower bolts from both rear shocks.

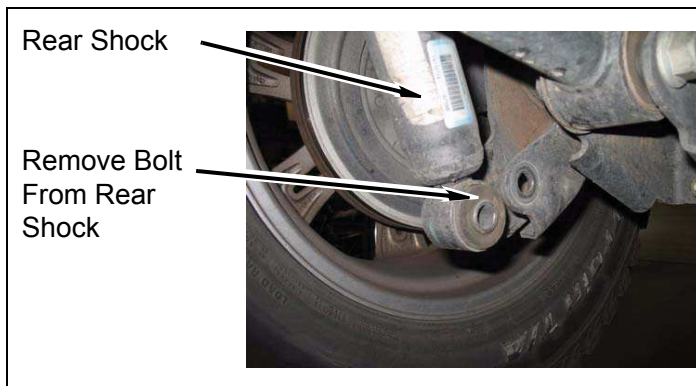

6. Remove ABS lines from there clips and ensure that there is plenty of slack in the ABS & brake lines when lowering axle housing.

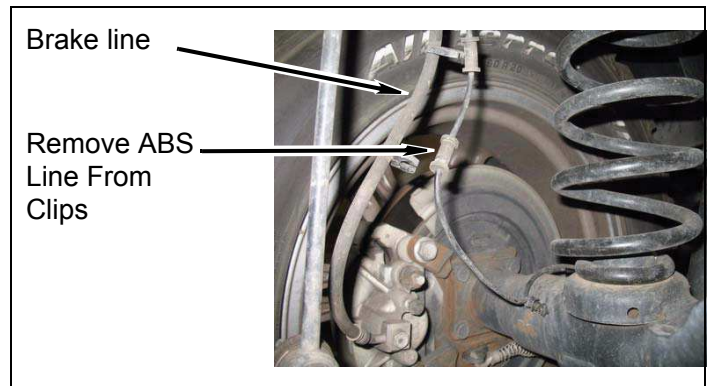

7. Carefully lower rear axle until rear coils come free from upper mount. Proceed by removing the rear coils from the rear axle.

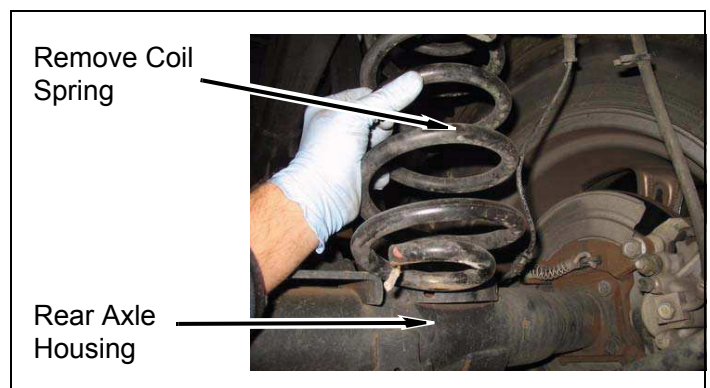

8. Removing rear coil spring Isolator from both coil spring.

Install Rear Coil Spacer Kit

1. Place *kit rear coil spring spacer* on both rear coil springs. Place rear coil springs back onto rear axle and frame mounts.

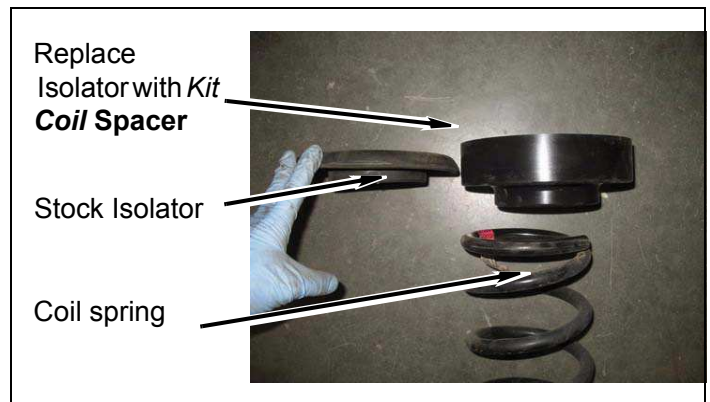

2. Install two lower bolts into both rear shocks. (**Note:** Careful when compressing rear axle, the load is

much greater now that the *kit coil spacer* is in place.)

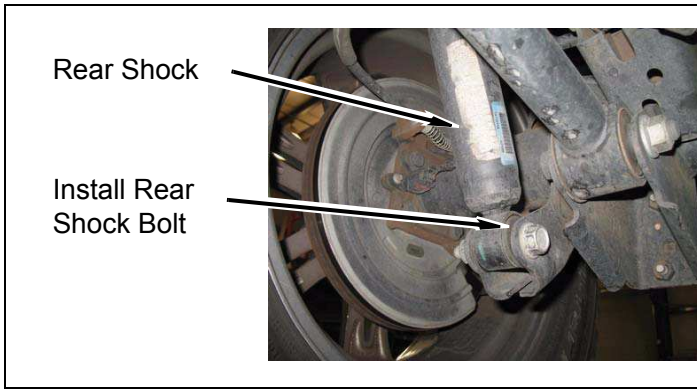

3. Install ABS lines back into there clips.
4. install two lower nuts into both rear sway bar end links.

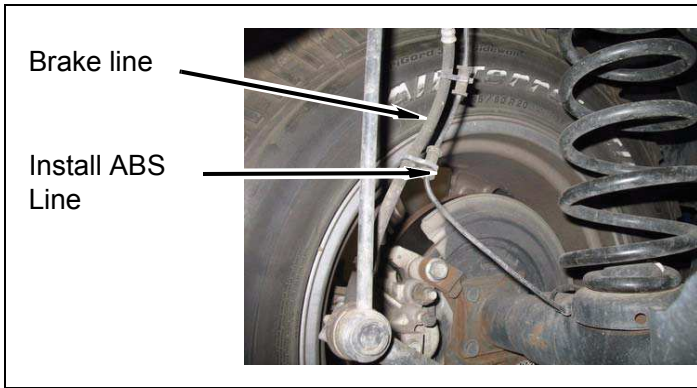

5. Install rear wheels onto vehicle with lug nuts. Snug, but DO NOT TIGHTEN.
6. Using hydraulic floor jack, raise rear of vehicle and remove jack stands. Slowly lower vehicle onto ground.
7. TORQUE rear lug nuts to specification.
- 8.

After Completing Installation

Engine Compartment

1. Connect both battery cables. Connect positive cable first, then negative cable.

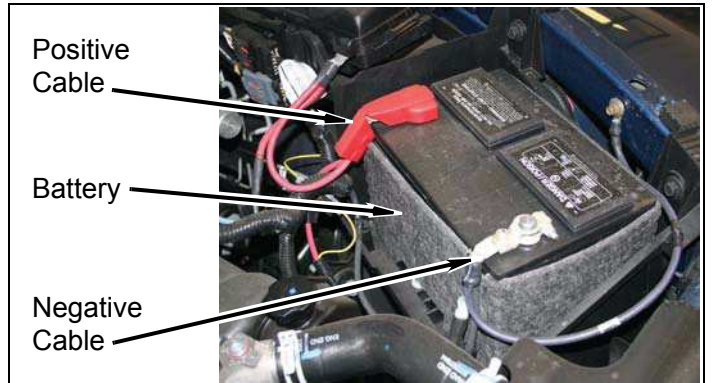

Miscellaneous

1. Apply *kit label* (warning) onto dashboard in plain sight of all vehicle occupants.
2. Adjust headlights.
3. Check all fasteners to ensure they are tight.
4. Ensure all wires, hoses, cables, etc. are properly connected and there is ample slack.
5. Align vehicle to OE specifications. Retain alignment results.

Dynamic Vehicle Check

1. Check steering and suspension in all positions to ensure that there is no bind and adequate clearance between all moving, fixed, and heated members. Check operation of clutch, brake system, and parking brake. Check operation of transmission and transfer case. Ensure there is full engagement in all gears and 4WD ranges. Check battery connections and electrical component operations. Test-drive vehicle.

⚠ WARNING

Retorque all fasteners after 500 miles and after off road use. All suspension lift components should be visually inspected and fasteners retorqued during routine vehicle servicing.

⚠ CAUTION

Performance Automotive Group does not recommend any particular wheel and tire combinations for use with its suspension lifts and cannot assume responsibility for the customer's choice of wheels and tires. Refer to your owner's manual for recommended tire sizes and warnings related to the use of oversized tires. Larger wheel and tire combinations increase stress and wear on steering and suspension components, which leads to increased maintenance and higher risk for component failure. Larger wheel and tire combinations also alter speedometer calibration, braking effectiveness, center of gravity, and handling characteristics. Consult an experienced local off road shop to find what wheel and tire combinations work best with your vehicle.

NOTE

All warranty information, instruction sheets, and other documents regarding the installation of this product must be retained by the vehicle owner. Information contained in the instructions and on the warranty card will be required for any warranty claims. The vehicle owner needs to understand the modifications made to the vehicle and how they affect vehicle handling and performance. Failure to provide the customer with this information can result in damage to the vehicle and severe personal injury.

Kit Parts List

Qty. Description

- 2 - Front Coil Spacers
- 2 - Rear Coil Spacers