

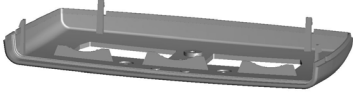

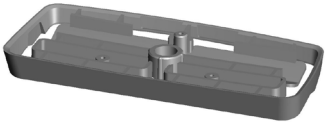





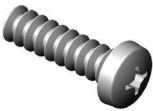

# 3RD GEN CHALLENGER INSTALLATION INSTRUCTIONS

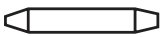
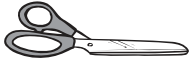

Contents of Package			
#	Component	Picture	Qty.
1	Pod, top		1
2	Pod, bottom		1
3	Pod, pedestal		1
4	Faceplate		1
5	Tape, adhesive	(No Picture)	1
6	#10 X 3/4" Screw		1
7	#10, Washer		1
8	#6 x 5/16, Screw		3
9	#6, Lock washer	#-9 	3

10	Isopropel Alcohol Wipe (IPA)	(No Picture)	1
11	Primer 94	(No Picture)	1
12	Keys Nut		1

TOOLS REQUIRED			
Trim removal tool		Scissors	
Drill		1/16" drill bit	
#2 Phillips Screw Driver		#10 drill bit	
Dremel™ Tool set			

**NOTE:** This pod was designed for Full Sweep and Short Sweep Electric Gauges. This installation instruction does not cover the following:

- Installation of the respective gauge wire harnesses into the vehicle. Especially as it relates to the installation of the harness into the engine compartment,
- This mounting solution, is targeted for 2-1/16" short sweep electric and 2-1/16" full sweep electric gauges.
- Prior to performing a full installation, we recommend to do a dry install without attaching it to the car. This will allow you to get familiar with the product.

# 3rd GEN CHALLENGER INSTALLATION INSTRUCTIONS

This mounting solution offers two basic types of installation method:

## **E-Z INSTALLATION:**

The mounting solution is attached to the dash board by using the supplied heavy duty double sided adhesive tape. This does not require a mechanical alteration of the dash board. This requires a thorough preparation of the dash board with isopropyl alcohol (IPA) and primer. (Both are provided)

The routing of the wire harness would then run on top of the dash board.

## **PERMANENT INSTALLATION:**

The mounting solution is attached to the dash board by using the supplied mounting hardware. This requires permanent mechanical modification of the dash board. The required modification consists of drilling two holes into the dash board.

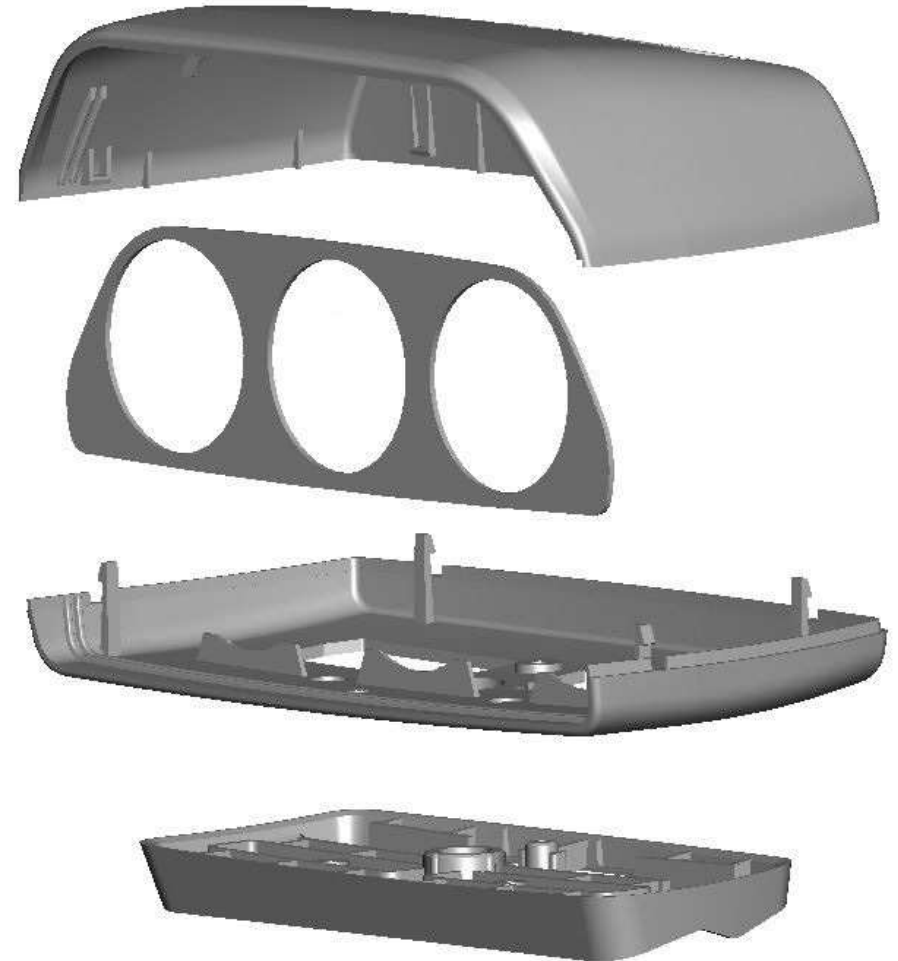

Since this installation requires creating one opening in the dash board, a second opening in the dash board would allow for the wire harness to be HIDDEN.

**THIS MODIFICATION IS NOT REVERSIBLE!**

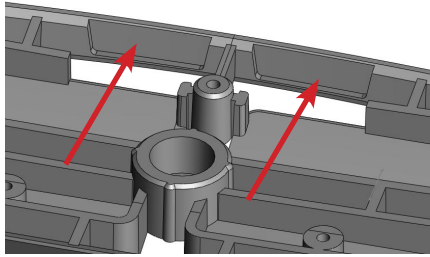
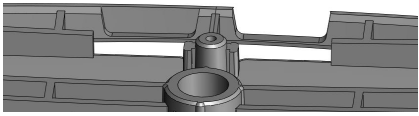
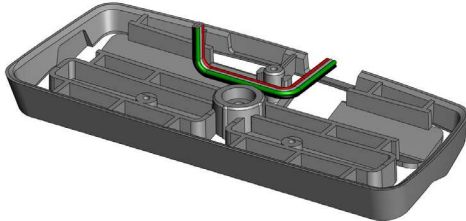
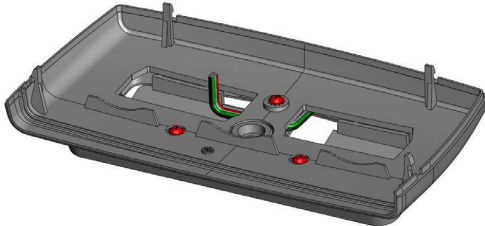

Exploded view of the assembly (without gauges):

POD PREPARATION/ E-Z INSTALLATION		
#	DESCRIPTION	PICTURE
1	<p>Create an opening for the gauge wire harness to exit the pedestal:</p> <p>There are two sections where the wall is intentionally kept thinner to create a template for the opening.</p> <p>For starters open one section to determine if there is enough room for the wire harnesses to exit. If needed, make a second opening.</p>	
	<p>Using a DREMEL™ or other suitable tool, and a suitable bit, GRADUALLY create an opening in the back wall until all gauge wiring harnesses fit through the opening.</p>	
2	<p>Lay wiring for all three gauges into the pedestal with any gauge connectors going towards the gauges.</p> <p>Tip: Label each set of wires as to what gauge it will go to.</p>	
3	<p>Feed the wire wiring through the openings in the bottom piece.</p> <p>Put the bottom piece over the pedestal and secure it with the three #6 screws and #6 star washers. <b>Take care not to pinch any wires in the step.</b></p> <p>Tighten the three #6 screws. Torque not to exceed: 5 in/lbs</p>	

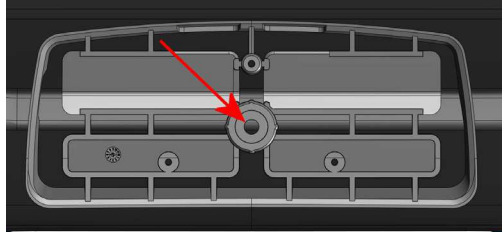
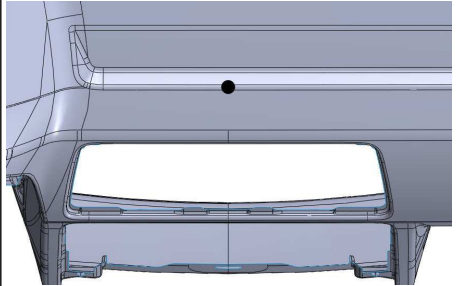
POD PREPARATION/ PERMANENT INSTALLATION		
#	DESCRIPTION	PICTURE
1	<p>Using a trim removal tool, remove the center air vents on the dash.</p>	
2	<p>Place the provided pedestal on the dashboard. The pedestal will be centered over the air vent. Line up the hole in the center of the pedestal with the gap between the two air ducts.</p>	
3	<p>Mark the center for the hole that will be used for the mounting screw.</p> <p><b>MAKE SURE THAT THE HOLE WILL BE EXACTLY IN BETWEEN THE TWO AIR DUCTS!</b></p>	
4	<p>Create the hole for the center mounting screw.</p> <p>Pre-drill using a 1/16" drill Use a 13/64" (or #10) drill bit to drill to final size.</p>	

## E-Z INSTALL CONTINUED

### Dashboard preparation:

The following shows the approximate location of the pod on the dashboard. Prior to committing the pod to its final location via the double sided tape perform a test fit.



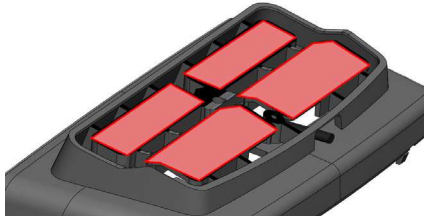
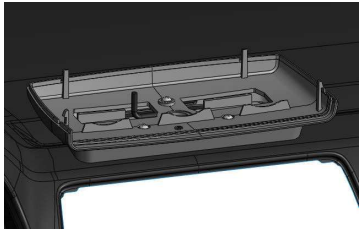

<b>4</b>	Wipe dust off the dash board Wipe the dash board with IPA Wipe the dash board with the primer	No Picture
----------	-----------------------------------------------------------------------------------------------------	------------

To Mount the pedestal/bottom piece sub-assembly to the dash board:

<b>5</b>	Wipe dust off the mounting pads on the bottom piece. Scuff the mounting pads on the bottom of the pedestal with an abrasive pad (similar to 3M™ Scotchbrite™) Wipe the mounting pads on the bottom of the pedestal with IPA Wipe the mounting pads on the bottom piece with the promoter	
<b>6</b>	Peel off the protective layer on the double sided adhesive tape on one side only. Apply tape to the mounting pad surfaces on the bottom of the pedestal.	No Picture
<b>7</b>	Remove protective layer from 2nd side of tape. Apply assembly to dash  * Skip to step #10 on following page for continued instructions.	

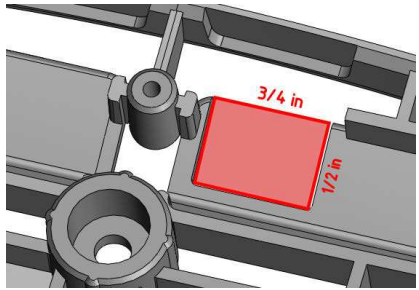

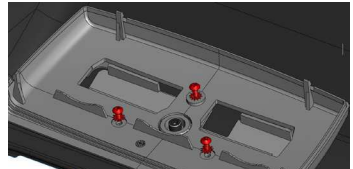
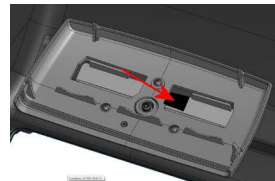
## PERMANENT INSTALL CONTINUED

<b>5</b>	Create an additional opening in the pedestal. Using a DREMEL™ or other suitable tool, and a suitable bit, GRADUALLY create an opening in the floor of the pedestal base until all three harnesses fit through the opening. <b>NOTE:</b> Depending, on what gauges you plan to install, the total thickness of the gauge wire harness may vary. We recommend to start out with a smaller opening and size it as needed.	
<b>6</b>	Place the pedestal on dash and TEMPORARILY insert the #10 mounting screw, which will locate the pedestal on the dash board. Then mark the opening with a marker and remove the #10 screw and the pedestal. Using a DREMEL™ or other suitable tool, and a suitable bit, GRADUALLY create an opening in the dash until all gauge wiring fits through the opening	
<b>7</b>	Place the pedestal back on the dash and secure it using the #10 screw, washer and #10 keps-nut.  Torque: not to exceed 5 in/lb	
<b>8</b>	Mount the bottom piece on the pedestal, using the three #6 screws and #6 star washers.  Torque: not to exceed 5 in/lb	
<b>9</b>	Feed the gauge wiring through the dash board, pedestal and bottom piece.  Continue with step 10.	

# 3RD GEN CHALLENGER INSTALLATION INSTRUCTIONS

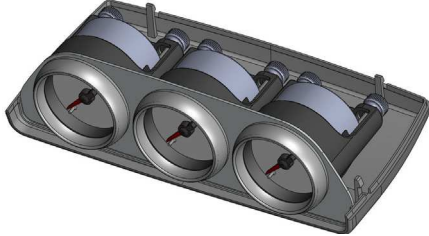
## Final Assembly:

10	<p>Insert three 2" gauges into the face plate. It does not matter what gauge goes into what opening of the face plate. Attach the three gauges to the face plate by using the mounting brackets and mounting hardware that came with each of the gauges. Make sure the gauges are aligned horizontally.</p>	
11	<p>Set the gauge/face plate assembly into the bottom piece.</p> <p>The face plate fits into the receiver groove that runs along the bottom piece.</p>	
12	<p>Connect each gauge with its respective wiring.</p>	<p>No Picture</p>

13	<p>Take the top piece and snap on to the bottom piece.</p>	
<p>This does require that you guide the gauge/face plate assembly into the groove in the top piece.</p> <p>The top piece is held in place by four heavy duty snap hooks.</p>		

### Disassembly / Removal of the top piece:

- The top snaps to the bottom piece via 4 heavy duty snap hooks.
- The receiver features are in the top half.
- The snap hooks are in the bottom half.

In order to remove the top from the bottom, insert a very small screwdriver into one of the small slots and push the snap hook inward slightly.

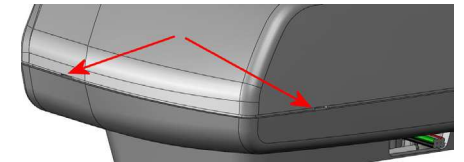

### SERVICE

For service send your product to Auto Meter in a well packed shipping carton. Please include a note explaining what the problem is along with your phone number. If you are sending product back for Warranty adjustment, you must include a copy (or original) of your sales receipt from the place of purchase.

### 12 MONTH LIMITED WARRANTY

Auto Meter Products, Inc. warrants to the consumer that all Auto Meter High Performance products will be free from defects in material and workmanship for a period of twelve (12) months from date of the original purchase. Products that fail within this 12 month warranty period will be repaired or replaced at Auto Meter's option to the consumer, when it is determined by Auto Meter Products, Inc. that the product failed due to defects in material or workmanship. This warranty is limited to the repair or replacement of parts in the Auto Meter instruments. In no event shall this warranty exceed the original purchase price of the Auto Meter instruments nor shall Auto Meter Products, Inc. be responsible for special, incidental or consequential damages or costs incurred due to the failure of this product. Warranty claims to Auto Meter must be transportation prepaid and accompanied with dated proof of purchase. This warranty applies only to the original purchaser of product and is non-transferable. All implied warranties shall be limited in duration to the said 12 month warranty period. Breaking the instrument seal, improper use or installation, accident, water damage, abuse, unauthorized repairs or alterations voids this warranty. Auto Meter Products, Inc. disclaims any liability for consequential damages due to breach of any written or implied warranty on all products manufactured by Auto Meter.

FOR SERVICE SEND TO: **AUTO METER PRODUCTS, INC.** 413 W. Elm St., Sycamore, IL 60178 USA • (866) 248-6357 • Email us at [service@autometer.com](mailto:service@autometer.com) • [www.autometer.com](http://www.autometer.com)