

INSTALLATION INSTRUCTIONS PRNDL PLUS

2650-1705-00

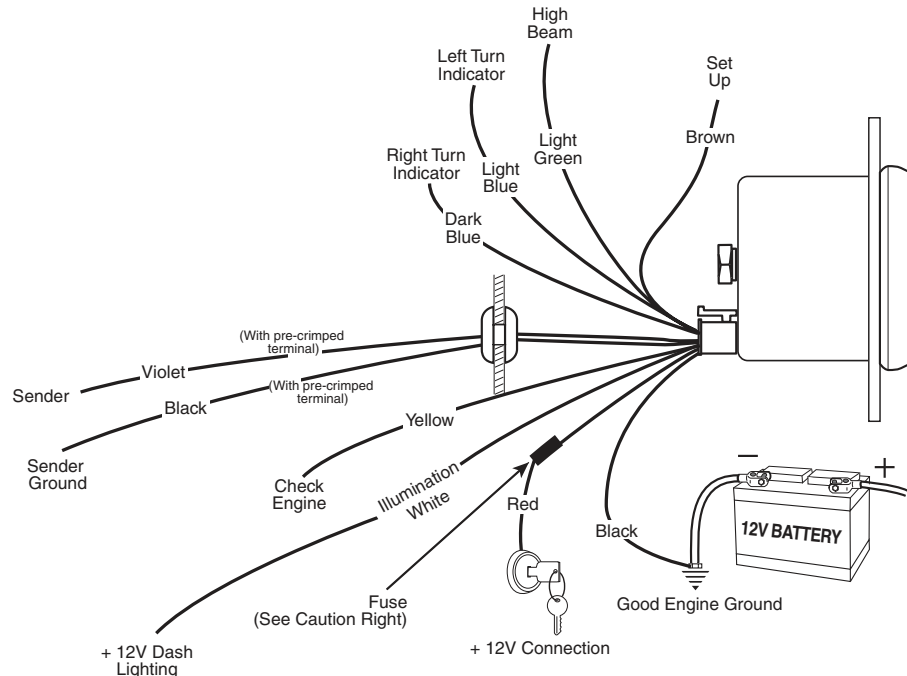

CAUTION!
As a safety precaution, the +12V terminal of this product should be fused before connecting to the 12V ignition switch. We recommend using a 3 Amp, automotive type fuse.

Wiring Gauge

The wire colors on this product were selected to best match the most popular aftermarket wire harnesses, steering columns, and GM vehicles to simplify installation and wire color matching, though this can be used on nearly any 12 volt, negative ground vehicle.

- Red:**..... +12V, (key on power). This can be connected to the same power supply you are using for your gauges, or to its own 3 Amp fused power source.
- Black:**..... Engine ground.
- Black:**..... Transmission gear position sender ground
- Yellow:**..... Check engine light signal from your engine computer (if equipped).
- White:**..... Lighting power from instrumentation/dash lights.
- Violet:**..... Transmission gear position sensor signal.
- Light Green:**.. High beam indicator (this is power from high beam switch).
- Brown:**..... Calibration set-up wire (only used during set up of gauge during installation). Momentary switch to ground.
- Light Blue:**.... Left turn indicator (this is power from your left turn signal circuit).
- Dark Blue:**.... Right turn indicator (this is power from your right turn signal circuit).

Check Engine Light

This will require checking the wiring diagram pertaining to the computer (ECM, PCM, ECU) that you are using. To activate the CEL, the yellow wire to the gauge gets grounded by the computer. In other words, this is a ground activated circuit. If your vehicle is not computer equipped, then you may simply seal the end of the wire, and do not use.

High Beam Indicator

This will require checking your vehicle or aftermarket (if used) wire harness diagram. To activate the Hi Beam, the light green wire gets powered by the hi beam circuit. In other words this is a power activated circuit.

Left Turn Signal Indicator

This will require checking your vehicle or aftermarket (if used) wire harness diagram. To activate the Left Turn indicator, the light blue wire gets powered by the left turn circuit. In other words this is a power activated circuit.

Right Turn Signal Indicator

This will require checking your vehicle or aftermarket (if used) wire harness diagram. To activate the Right Turn indicator, the dark green wire gets powered by the right turn circuit. In other words this is a power activated circuit.

Helpful tips to determine which of your factory wires are turn signal, and high beam:

If you have easy access to the wires behind your gauge panel (most easily done with gauge panel removed), you can use a simple test light. With power turned on, you can turn on your left turn signal, and probe each, un-used wire and when your test light starts to flash with the turn signals, you have found the correct wire. Repeat the same for the right turn signal. For high beam, you can leave power off, but turn on your head lights. Activate your high beams, and use your test light to determine which wire has power. When you find it, deactivate your high beams to make sure the test light goes out. If it does not go out, then you have not found the correct wire yet. When performing the above tests, make sure your test light has a suitable electrical ground on the vehicle. A poor ground connection for your test light can adversely affect the outcome of these tests.

Gauge Lighting

This gauge has no actual back lighting as it is a digital display, however when power is applied to the white wire, the digital display brightness will be reduced by about 30%. If this white wire is connected to a dash lights rheostat, or the Auto Meter 9114 dimming module, the display will also be able to be dimmed further. When no power is detected on the white wire (either lights turned off, or in some cases dimmed 100%, the digital display will return to full brightness.

Mounting Transmission Gear Position Sensor:

See Universal Gear Position Sensor section of instructions. Page 3.

Wiring Transmission Gear Position Sensor:

After the sending unit has been installed and the black and purple wire have been fed through the firewall, attach the purple and black wire to the connector housing and add the lock.

1. Insert the terminals into the connector housing. It does not matter on what side the black and purple wire goes. The sensor is not polarity sensitive.

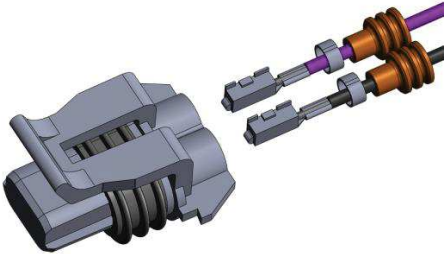

2. Add blue lock.

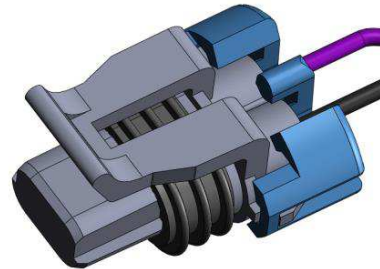

3. Plug into the mating connector on the sensor.

Mounting the gauge:

This gauge is meant to be mounted into a 2-1/16" hole, the same as most other 2-1/16" Auto Meter in-dash gauges. You may want to delay final mounting until after the gauge has been calibrated so that you have access to the brown wire for calibration. Or you may choose to final mount your gauge, then calibrate in which case you will want to maintain access to the brown calibration wire after mounting.

Calibration/Set up:

The PRNDL gauge must be set up, or calibrated before use. To do this, the sender unit must be installed on the transmission linkage, the transmission linkage must be properly adjusted, and the gauge must be wired up. Before getting started, determine what letters and numbers you want to use. The list of available options can be found below. This gauge comes with the following letters and numbers that can be used in programming your gauge:

P, R, N, D, L, od, O, 5, 4, 3, 2, 1.

Any of the above can be easily skipped by letting the number or letter time-out while flashing, while in calibration mode. Some common examples of what you might use, are listed below, however you can program it to read any way you like.

A typical 4-speed over-drive automatic may use: P, R, N, od, D, 2, 1.

Or may use : P, R, N, D, 3, 2, 1. another option would be P, R, N, O, 3, 2, 1. In this case, the large-case "O" would stand for over drive.

A typical 3-speed automatic may use P, R, N, D, 2, 1, or P, R, N, 3, 2, 1.

A Powerglide 2-speed might use P, R, N, D, L, or P, R, N, D, 1, or P, R, N, 2, 1.



These are just a few examples, and you can program however you choose. It also does not matter if your vehicle is equipped with a reverse valve body. You simply have to be in the correct gear when you capture the reading that you are programming.

PROGRAMMING the Gear Selection Display:



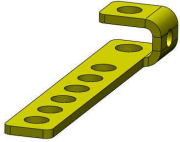
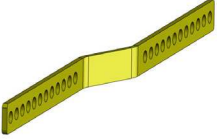
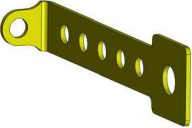
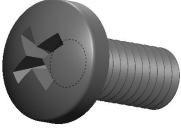

During the set up procedure it will be necessary to connect the brown set up wire momentarily to ground. This can be done by connecting it to one terminal of a normally open, momentary push button switch, and connecting the other terminal of the button to ground. Alternatively, the bare end of the wire can be manually touched to a good ground. When doing this, make a solid connection to ground for one second, then remove the wire from ground. The power to the gauge needs to be off in order to enter calibration mode. Connect the set up wire to ground (or push and hold calibration button), then switch power on to the gauge, (hold ground connection on brown wire for 1 second after power up) then remove the connection to ground. The display will flash 'P' for 5 seconds. Connect the brown set up wire momentarily to ground and release. The 'P' will now be on steady until your next button push. Put the vehicle in Park and connect the brown set up wire momentarily to ground to capture the Park setting. Then the gauge will flash 'R'. Connect the brown wire momentarily to ground and release. The 'R' will now be on steady until your next button push. Move gear position selector to reverse and connect brown set up wire momentarily to ground to capture the reverse settings. Repeat for all gear positions. If a letter or number is to be skipped, simply do not connect the wire to ground while the character is flashing. After 5 seconds it will move on to the next position.

INSTALLATION INSTRUCTIONS UNIVERSAL GEAR POSITION SENSOR

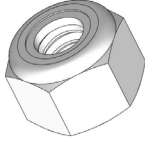
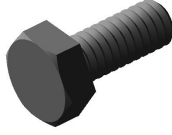

Component	Picture	Qty.
Sender, with harness		1
Bracket		1
Arm		1
Linkage		1
Shift bracket		1
Shipping kit		1
Screw, #8-32		1

TOOLS REQUIRED: Hacksaw, Metal file, a drill, a drill bit set, Phillips and flat head screw driver, a socket set or open end wrenches. A well lit workbench with a vise would also be helpful.

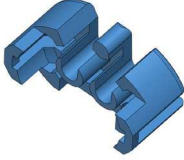
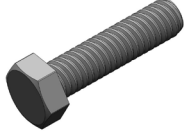
Stop-nut, 1/4-20		2
Screw, 1/4-20, 0.875"		2
Spacer		1
Washer, plastic		4
Connector housing		1
Lock		1
Screw 5/16" - 18 X 1.25"		1

Basics

The sending unit is mounted to the transmission/oil pan flange via a rugged bracket and connects to the shift select lever on the transmission through a linkage.

While there are many installation scenarios possible, the following four pictures give you an overview of the more common ones. (some of the fasteners that are already on the vehicle are not shown).

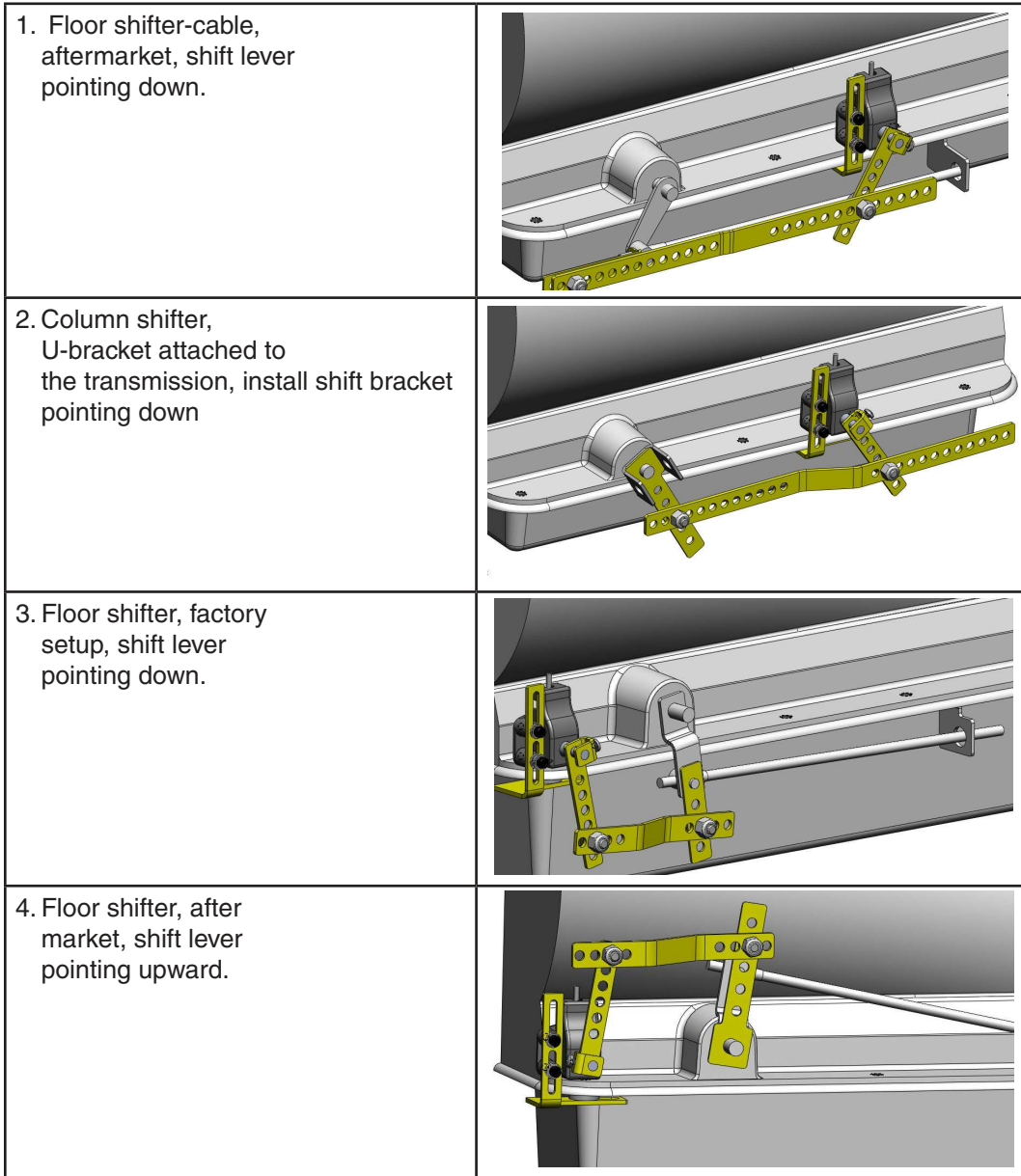

By making simple modifications to the shift bracket and the linkage, the sender can be adapted to fit to many transmission configurations. The linkage comes with a preset offset. Adjustments can be made by simply increasing or decreasing the pre-existing bends.

Shift Bracket

linkage

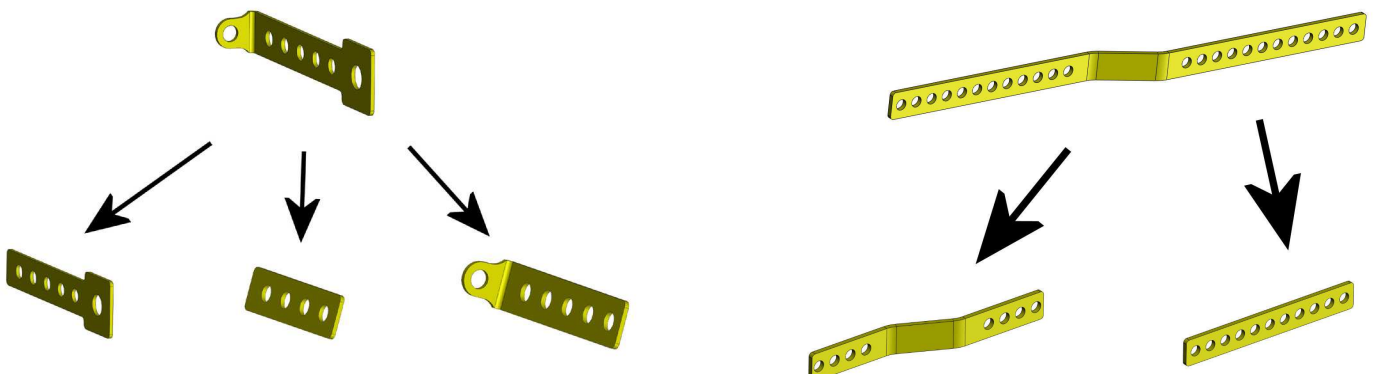

Mounting the Sender to the Transmission

Mount the sender to the sender bracket by using the two #8 screws, #8 washers and #8 lock washers. The screws will engage into brass inserts that are part of the sender housing.

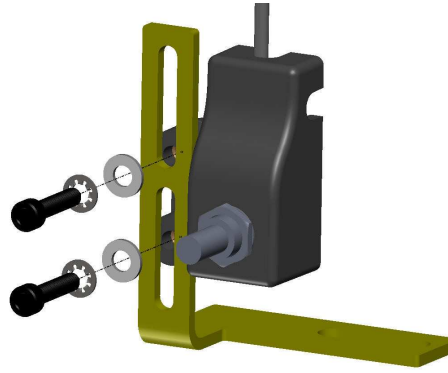

Find location for the sender on the transmission. Either in front of the shifter lever (1) or behind the shifter lever (2)

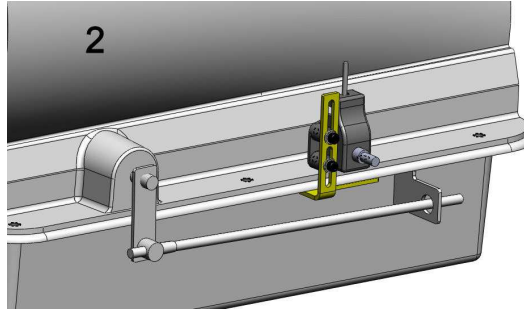
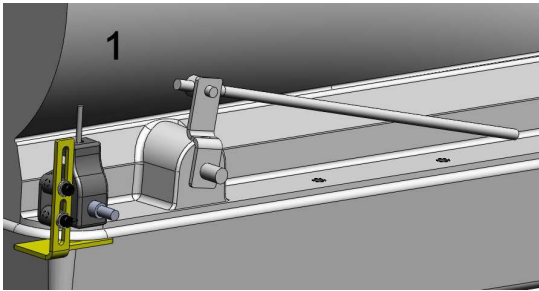

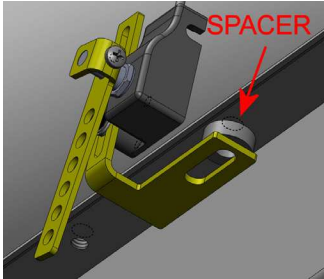
DESCRIPTION	PICTURE
<p>Mount the sender via the bracket to the underside of the transmission/oil pan flange with a 5/16 bolt. The exact spot depends on your application. Make sure that the "foot" of the bracket is aligned with the transmission. The spacer is used in applications where the transmission pan has a lip that needs to be cleared.</p>	 A close-up 3D diagram showing the yellow bracket being secured to a metal flange. A red arrow points to a small grey spacer being placed between the bracket and the flange. The word "SPACER" is written in red above the spacer.

Locate the shift bracket. Using the previous **BASICS SECTION** for ideas, determine how you may need to modify this bracket to make it work for your application. In several cases this bracket can be secured to your existing shift lever via the existing shift lever.

Orientation of the sender shaft and position of the arm:

The arm can be attached to the sender shaft with the #8 screw pointing either to the left or the right and without having the sender firmly mounted to the transmission. Having the #8 screw on the left or the right, will affect the offset between the arm and the shift lever on the transmission. If needed the factory offset in the linkage can be adjusted by simply increasing or decreasing the bends.

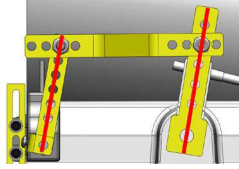
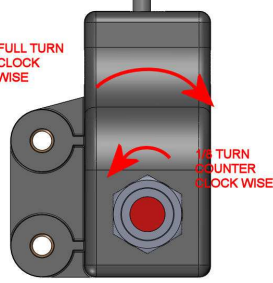
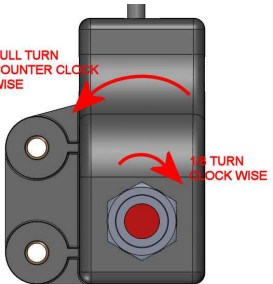
DESCRIPTION	PICTURE
<p>IMPORTANT: Start with putting the transmission in Park. Once the shift lever and arm are connected with the linkage, the arm should be close to parallel with the shift lever, one possible example is shown to the right.</p>	
<p>1. If the arm needs to point down: Turn the sender shaft clock wise until it stops. Then turn the sender shaft back counter clock wise 1/8 of a full turn.</p> <p>NOTE: Place the arm on the sender shaft and tighten it in a position where it is as parallel to the shift lever as possible.</p>	
<p>2. If the arm needs to point up: Turn the sender shaft counter clock wise until it stops. Then turn the sender shaft clock wise 1/8 of a full turn.</p> <p>NOTE: Place the arm on the sender shaft and tighten it in a position where it is as parallel to the shift lever as possible.</p>	

Connect the linkage to the arm and bracket:

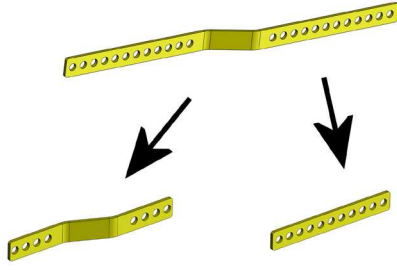
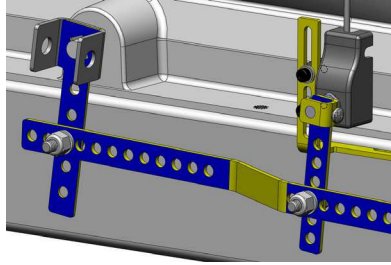
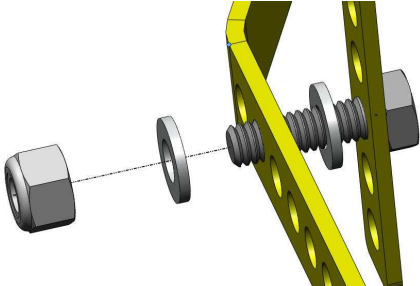
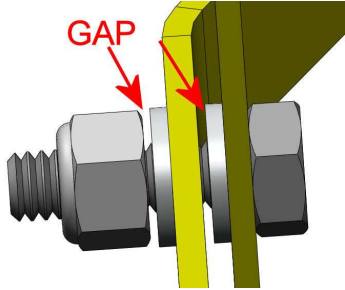
DESCRIPTION	PICTURE
<p>Also depending on your setup, you may have to make an adjustment to the linkage to allow for a clean transfer of motion from the shift lever to the sender. That includes the length of the linkage.</p>	
<p>Make sure the offset in the linkage is adjusted to have the mating surfaces (highlighted in blue) in the linkage, arm and bracket as parallel as possible.</p>	
<p>Attach linkage fasteners. Regardless of your particular setup, below is a picture how the linkage gets attached to the arm AND the bracket. Use the two provided plastic washers, the 1/4 nut and screw.</p>	
<p>IMPORTANT: Do NOT over tighten the fasteners and leave small gaps (min 0.02"; max 0.05")</p>	

Feed the two sender wires , (purple and black) coming from the sender harness, through the fire wall and attach them to the connector. Secure the sender wire to appropriate places on the vehicle to prevent it from getting damaged by heat or any moving components.

Connect the sender and gauge harness, program the gauge.

SERVICE

For service send your product to Auto Meter in a well packed shipping carton. Please include a note explaining what the problem is along with your phone number. If you are sending product back for Warranty adjustment, you must include a copy (or original) of your sales receipt from the place of purchase.

12 MONTH LIMITED WARRANTY

Auto Meter Products, Inc. warrants to the consumer that all Auto Meter High Performance products will be free from defects in material and workmanship for a period of twelve (12) months from date of the original purchase. Products that fail within this 12 month warranty period will be repaired or replaced at Auto Meter's option to the consumer, when it is determined by Auto Meter Products, Inc. that the product failed due to defects in material or workmanship. This warranty is limited to the repair or replacement of parts in the Auto Meter instruments. In no event shall this warranty exceed the original purchase price of the Auto Meter instruments nor shall Auto Meter Products, Inc. be responsible for special, incidental or consequential damages or costs incurred due to the failure of this product. Warranty claims to Auto Meter must be transportation prepaid and accompanied with dated proof of purchase. This warranty applies only to the original purchaser of product and is non-transferable. All implied warranties shall be limited in duration to the said 12 month warranty period. Breaking the instrument seal, improper use or installation, accident, water damage, abuse, unauthorized repairs or alterations voids this warranty. Auto Meter Products, Inc. disclaims any liability for consequential damages due to breach of any written or implied warranty on all products manufactured by Auto Meter.

FOR SERVICE SEND TO: **AUTO METER PRODUCTS, INC.** 413 W. Elm St., Sycamore, IL 60178 USA (866) 248-6357

Email us at service@autometer.com

<http://www.autometer.com>