

ROTA LIGHT BAR MOUNTING INSTRUCTIONS

Part No's: 210871, 210872 & 210874

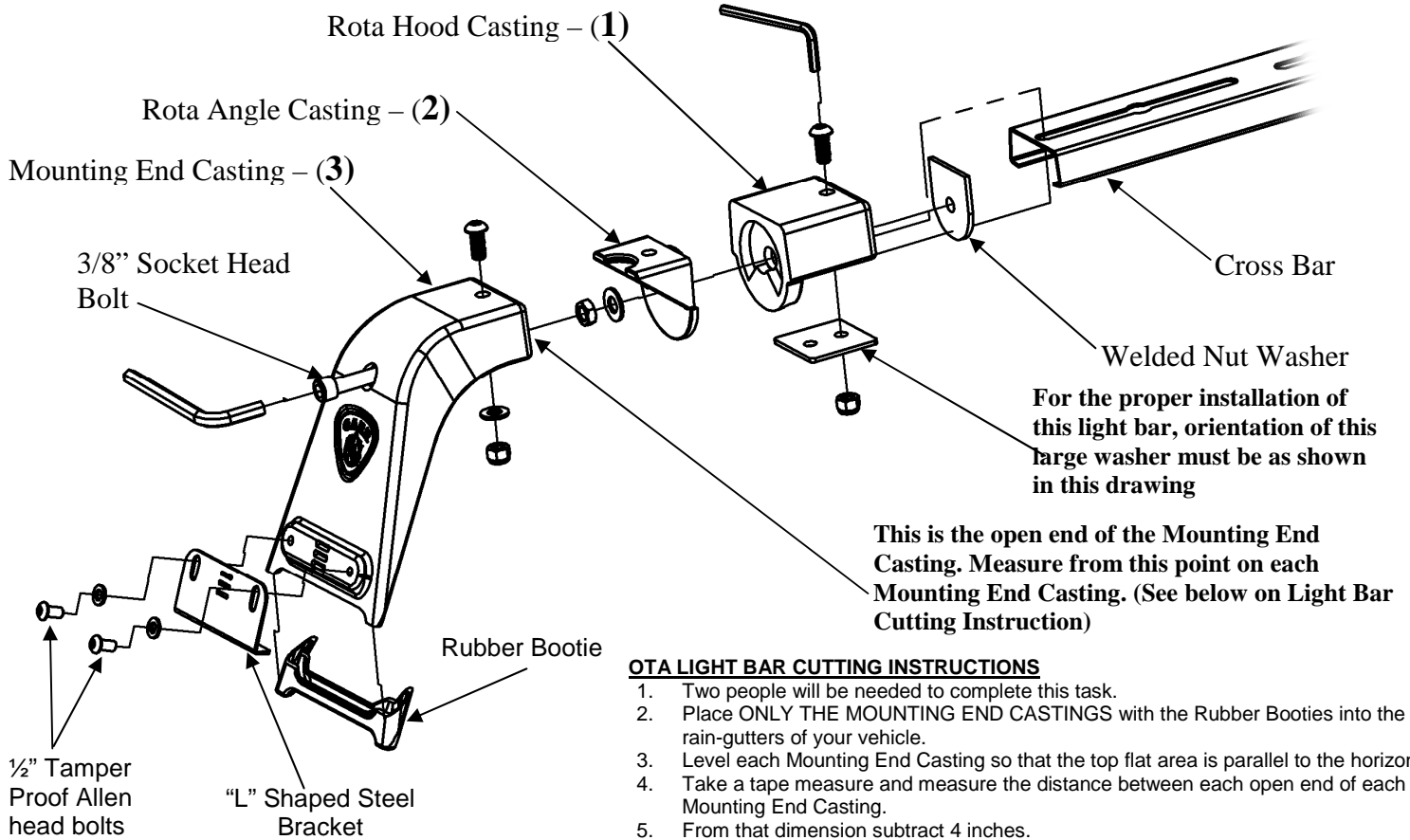

For the proper installation of this light bar, orientation of this large washer must be as shown in this drawing

This is the open end of the Mounting End Casting. Measure from this point on each Mounting End Casting. (See below on Light Bar Cutting Instruction)

OTA LIGHT BAR CUTTING INSTRUCTIONS

- Two people will be needed to complete this task.
- Place ONLY THE MOUNTING END CASTINGS with the Rubber Booties into the rain-gutters of your vehicle.
- Level each Mounting End Casting so that the top flat area is parallel to the horizon.
- Take a tape measure and measure the distance between each open end of each Mounting End Casting.
- From that dimension subtract 4 inches.
- Subtract that total from the total length of the bar, which is 56".
- Take the difference and divide it by two.
- The amount divided by two is the amount you will cut off each end of your bar.
- Measure and mark a line on both ends of the steel bar using the above dimension you have just figured.
- Clamp one end of a bar into a vise. (Be careful not to scar the light bar).
- Using a hacksaw, cut carefully along the marked lines. (If a vise is not available, put the bar on a table, secure tightly and cut).
- Repeat steps 9-11 to cut the other end of the bar.

MATERIALS NEEDED: Hammer, center punch, pencil
MATERIALS FURNISHED: One hardware pack, two end castings, four Rota castings, cross bar, instruction page.

SPECIAL NOTE: VEHICLES NOT HAVING RAIN GUTTERS WILL REQUIRE RAIN GUTTER KITS:

- #220041/#220042 - 76-93 Chevy S-10/Sonoma P/U, Blazer/Jimmy, , 04-08 F-150 N.Body, 84-02 Isuzu Trooper, 97-02 Mitsub. Mont.Sport, 05-16 Toyota Tacoma/Prerunner Cr.Cab, 07-16 Tundra, 05-07 4-Runner, 07-16 FJ Cruiser
- #220051/#220052 - 04-16 Chevy Colorado/GMC Canyon, 97-04 Dodge Dakota, 99-16 Ford Super Duty All Cabs, 00-05 Ford Excursion, 91-02 Isuzu Rodeo/Amigo, 05-16 Jeep Grand Cherokee, 83-93 Mazda B-Series P/U, 98-01 Nissan Frontier Reg.Cab, 86-01 Pathfinder, 86-97 Nissan Hard Body P/U, 89-95 Toyota P/U, 93-99 T-100, 84-04 Toyota 4-Runner, 96-04 Toyota Tacoma/Prerunner Crew Cab, 00-06 Toyota Tundra, 01-07 Toyota Sequoia, 06-10 Jeep Commander
- #220061/#220062 - 04-14 F-150, 00-16 Nissan Xterra-w/o Option Roof Rack, 04-11 Nissan Pathfinder, 02-16 Nissan Frontier Crew Cab, 14-16 Chevy/GMC Sierra/Silverado C/K P/U/FS, 03-13 Dodge 2500/3500, '09-13 Dodge FS 1500 P/U All Cabs
- #220541/#220542 - 00-13 Chevy/GMC Sierra/Silverado C/K P/U/FS, 02-09 Chevy Trail Blazer/Envoy , 02-13 Avalanche, 02-16 Denali Truck, 00-16 Chevy Tahoe/Suburban/Tahoe/GMC Yukon/Yukon XL, 02-08 Dodge FS 1500 P/U, Quad, 02-08 Dodge Quad 1500, 05-09 Dodge Durango, 05-16 Dodge Dakota,
- #221501/#221502 - 98-01 Dodge Quad Cab 1500 P/U, 98-02 Dodge Quad Cab 2500/3500 P/U, 94-02 Dodge 2500/3500 P/U Old Body Style, 94-01 Dodge P/U.
- #222741/#222742 - 91-01 Ford Explorer(not Eddie Bauer)/Mercury Mountineer, 91-94 Mazda Navajo.
- #223411/#223412 - 88-99 Sierra Silverado C&K P/U/FS, 92-99 Chevy Sub/Yukon/Tahoe, 93-98 Jeep Grand
- #220081-220082 - 14-16 Dodge Ram 1500-5500 All Cabs/All doors

WARNING!
THIS CARR LIGHT BAR IS DESIGNED TO HANDLE A TOTAL WEIGHT OF (20) LBS. ANY ADDITIONAL WEIGHT BEYOND THIS CAPACITY, MAY RESULT IN SERIOUS DAMAGE TO YOUR VEHICLE AND/OR ANOTHER VEHICLE.



Quality and Style that Endures

Follow the diagram and the written directions carefully for a proper, safe installation.

Should you encounter an unusual, unforeseen problem, contact our Technical Help Line
 7:00 AM – 3:00 PM Pacific Time
 (951) 719-1068
 Visit our web-site at www.CARR.com
 Carr Pattern Co., Inc.

ROTA LIGHT BAR MOUNTING INSTRUCTIONS

Part No's: 210871, 210872 & 210874

WARNINGS!

- ✓ Do not over tighten the nuts and bolts or damage to the castings and or stripping of the threads could result.
- ✓ FOR SAFE AND PROPER USAGE OF THIS PRODUCT, THE MOUNTING INSTRUCTIONS MUST BE FOLLOWED CAREFULLY AND COMPLETELY.
- ✓ The manufacturer and distributor of this product are in no way responsible for the consumer's failure to adhere to the warnings and directions of these instructions in the event of damage to the consumer's vehicle, other properties and or personal injury.
- ✓ DO NOT REMOVE the PVC tape from the light bar until cutting is completed. When cutting black bar leave plastic bag on and wrap a rag around bar before putting into a vise so no scratching of paint will result. Remove the PVC tape from the brackets (does not apply to black brackets). The light bar will not tighten properly unless the bar is straight across the cab.

1. **IMPORTANT: Cut the crossbar FIRST before proceeding to the next step! Refer to the Rota Light Bar Cutting Instructions on the other side.**
2. Place the black plastic booties on the feet of each casting.
3. Take the long 3/8" socket bolt and screw on to it the 3/8" jam nut all the way to the end of the threads and tighten down.
4. Place the head of the long socket bolt through the large hole in casting (3).
5. Leave the head of the long socket bolt extending all the way out of casting (3).
6. Place casting (2) inside of casting (3) and line up the two 5/16" holes.
7. Take the 5/16" Allen head screw and put it through both castings (3) and (2). Use the 5/16" washer and 5/16" nylon lock nut to securely tighten castings.
8. **NOTE: THE FRONT FACE OF CASTING (2) SHOULD BE STRAIGHT ACROSS THE FACE OF CASTING (3).** When the castings are securely tightened together, casting (2) should be protruding approximately 1/16" beyond casting (3).
9. Place a 3/8" flat washer on the long 3/8" socket bolt and now put the long socket bolt through the other hole in casting (2).
10. Place casting (1) on casting (2).
11. With the welded nut washer facing away from casting (2) place it all the way to the inside of casting (1).
12. Screw the long 3/8" socket bolt into the washer with the welded nut all the way, and lightly tighten. **NOTE:** Use the 5/16" Allen wrench through the large hole in casting (3) to tighten and loosen the rotating motion.
13. Repeat steps 1 through 11 for the other side.
14. With the holes in the bar, in the up position, take casting (1) and by squeezing the end of the bar, place casting (1) on the bar, until the inside top wall of the casting is flat against the bar.
15. Take a 5/16" Allen head screw and put it through the hole in casting (1), and the slot in the bar, with the head of the screw in the up position.
16. **IMPORTANT:** For some trucks when the bar is cut and put into casting (1), there may not be a slot left in the bar. If this is true, follow the next 11 steps.
 - a. With the black booties on the back of casting (3), place the entire casting assembly into the rain gutter of the vehicle.
 - b. Position the foot of the "L" shaped steel brackets underneath the rain gutter and line up the vertical slot of the bracket with the tapped hole in the casting. Insert (2) 1/2" tamper proof Allen head bolts with lock washers through the "L" bracket securing the bracket to the support casting.
DO NOT TIGHTEN
 - c. Place a screwdriver through the desired horizontal slot in the steel bracket, at the same time put the screwdriver into one of the three slots provided in the casting. **(Proper selection of the slots in the bracket and the slots in the casting will result in a tighter fit on the vehicle).**
 - d. Push the screwdriver against the casting and pry up against each bracket, one at a time, until both the casting and brackets are tightly secured in place. Tighten the two Allen head bolts. **CAUTION:** Prying up excessively could result in bending of the bracket or stripping the slots in the castings.
 - e. Follow the same procedure in steps a, b, c, and d, to secure the other casting to rain gutter.
 - f. By squeezing the ends of the bar put the bar back inside of casting (1).
 - g. With bar in castings, take a pencil and using the hole on top of casting (1), mark a circle on each end of the bar.
 - h. Take the bar out and drill a 3/8" hole through each marked circle. Deburring may be necessary.
 - i. Put the bar back into castings and use the other 5/16" Allen head screws and put them through the top holes in casting (1) and through the holes drilled in the bar. Take the two large flat washers and the 5/16-18 nylon lock nuts, as shown in diagram, and securely tighten bar to casting (1). **NOTE:** Be sure that the large washer is completely underneath casting (1).
 - j. The bar and casting assemblies should now be tightly secured to the vehicle.
 - k. Refer to step 29 for further instructions.
17. Take the large washer and put it inside the bar, with the 5/16" Allen head screw, going through the washer. **IMPORTANT:** Be sure that the large washer is completely underneath casting.
18. With the large washer in position, take a nylon lock nut and Allen wrench provided, and lightly tighten the bar to casting.
19. Follow the same procedure in steps 15, and 16 to attach other casting to the bar.
20. With both of the castings lightly tightened to the bar, take the entire bar and place the bar, with the castings, into the rain gutter of your vehicle.
21. Loosen, **DO NOT REMOVE** hardware on bar and casting.
22. Slide castings in or out on bar, so that each casting sets completely in rain gutters. **IMPORTANT:** Make sure that the bar is centered and that the bar is evenly divided into each casting and that each casting is directly across from each other.
23. Once again, take Allen wrench and tighten securely the bar to each casting.
24. Position the foot of the L shaped steel brackets underneath the rain gutter and line up the vertical slots of the L Shaped Steel Bracket with tapped holes in casting (2). Insert (2) 1/2" Tamper proof Allen head bolts with lock washers through the L Shaped Steel Bracket securing the bracket to casting (1). **DO NOT TIGHTEN!**
25. Place a screwdriver through the desired horizontal slot in the steel bracket, at the same time put the screwdriver into one of three slots provided in the casting. **(Proper selection of the slots in the bracket and the slots in the casting will result in a tighter fit on the vehicle.).**
26. Push the screwdriver against the casting and pry up against each bracket, one at a time, until both the casting and brackets are tightly secured in place. Tighten the two Allen head bolts. **CAUTION:** Prying up excessively could result in bending of the bracket or stripping the slots in the castings.
27. Follow the same procedure in steps 23 - 25 to secure other casting to the rain gutter.
28. The bar and casting assemblies should now be tightly secured to the vehicle.
29. **CAUTION: WHEN LIGHTS ARE INSTALLED ON YOUR BAR AND YOU WANT TO LOOSEN YOUR BAR TO ROTATE THE BAR DOWN, BE CAREFUL NOT TO LOOSEN TOO MUCH BECAUSE LIGHTS COULD CRASH INTO THE CAB OF THE TRUCK AND CAUSE DAMAGE TO THE TRUCK AND LIGHTS, AND DO NOT LOSE YOUR ALLEN WRENCH.**
30. Your light bar hardware may settle in. After 2 or 3 weeks of use, go back and re-tighten all hardware. A periodic check on all hardware is recommended.
31. To maintain the luster of your light bar, apply a polish on a regular basis.

Carr Pattern Co., Inc.
Warranty Policy

Finishes: Limited Lifetime

Structural Warranty: Limited Lifetime

Warranty Conditions:

- a. All warranties start from consumer's date of purchase.
- b. A new product will be sent out immediately to replace a warranty claim.
- c. The above guidelines apply only to the Original Purchaser.
- d. Original proof of purchase must be submitted for all warranty and returns issues.

Warranty Limitations:

- a. Warranty coverage extends ONLY to repair or replacement of the CARR product. This warranty does not cover the cost of labor, transportation, installation or removal of the product.
- b. Warranty coverage does not extend to damage caused by: collision, fire, theft, freezing, vandalism, riot, explosion or object striking the product, or misuse of the product and/or the vehicle on which the product is being installed.
- c. Warranty coverage does not extend to damage caused by: airborne fallout (chemicals, tree sap, etc.), stones, hail, earthquake, water or flood, windstorm, lightning, the application of chemicals or sealants subsequent to manufacture.
- d. Warranty coverage does not extend to damages caused by: normal wear and tear, abuse, modification or improper installation of the product.
- e. Warranty coverage does not extend to any economic loss or extra expense including (without limitation), payment for the loss of time or pay, inconvenience, storage, loss of vehicle use, vehicle rental expense, equipment rental expense, lodging, meals, or other travel costs.

Other Terms:

This warranty gives you specific legal rights and you may also have other rights that vary from state to state. CARR does not authorize any person to create for it any other obligation or liability in connection with its products. ANY IMPLIED WARRANTY OF MERCHANTABILITY OR FITNESS FOR A PARTICULAR PURPOSE APPLICABLE TO THIS PRODUCT IS LIMITED IN DURATION TO THE DURATION OF THIS WRITTEN WARRANTY. PERFORMANCE OF REPAIRS AND NEEDED ADJUSTMENTS IS THE EXCLUSIVE REMEDY UNDER THIS WRITTEN WARRANTY OR ANY IMPLIED WARRANTY. CARR SHALL NOT BE LIABLE FOR INCIDENTAL OR CONSEQUENTIAL DAMAGES RESULTING FROM BREACH OF THIS WRITTEN WARRANTY.*

*Some states do not allow limitations on how long an implied warranty will last or the exclusion or limitation of incidental or consequential damages, so that above limitations or exclusions may not apply to you.

Guarantee: Every attempt has been made to manufacture and distribute the finest quality products available. Our manufactured products are guaranteed to be free of defects due to workmanship or materials. Distributed products are subject to manufacturer's warranty only.