



Please read the following key points before installing this kit.

- 1 – Before performing the subframe connector installation, the vehicle must be completely assembled with all body and component parts installed (e.g. fenders, hood, quarterpanels, trunk, full interior, engine, glass, etc.). Basically, the subframe connectors should be one of the last components installed on your vehicle. Reason being is you want the vehicle settled with all of it's own final weight. The car's body is always in constant tension, with forces pushing or pulling within the chassis & body. You want to make sure these forces don't change after you install the subframe connectors. For example, if you installed subframe connectors before installing the engine and body panels this may result in having misaligned fenders, door panels and/or hood later on. The car must be in it's final state before the subframe connectors are installed.
- 2 – The subframe connectors must be installed on an alignment rack or floor ramps (all 4 wheels). The vehicle must be sitting on it's wheels at ride height in order to install the subframe connectors. Do not use a two-post lift, as this will load the chassis/body in the wrong points causing the chassis to tweak.
- 3 – If you your vehicle is equipped with torque boxes, please pay attention to step 3b of this manual. You may be required to purchase extra hardware in this case.

4010

Subframe Connectors 66-70 Chrysler B-Body

4011S & 4011L

Subframe Connectors 70-74 Chrysler E-Body



**Thank you for your purchase from our new line of Chrysler parts.
Please call us at (877) 4NO - ROLL if you have any questions
regarding the service or installation of your Hotchkis products.**

Subframe Connectors:

Your new subframe connectors will increase the overall rigidity of your chassis and improve handling and response. These engineered components connect the rear frame rails with the front subframe to simulate a complete full frame chassis.



Notes:

The subframe connector is essentially a Weld-In component, effectively connecting the front subframe and rear frame rails.

Before You Start:

The installation of these subframe connectors will require you to grind and weld. It is recommended that a trained professional install this product. Always wear eye protection when grinding or welding. Please read the entire manual before starting. All images will depict the driver side installation.

1. Raise Vehicle

It is best to install the subframe connectors at ride height. To do this properly, please use a 4-Post lift or alignment rack. Disconnect the negative battery cable.



2. Prepare Subframe Pieces for Welding

Subframe pieces come fully powder coated so you will want to first prep them for the welding process. Sand the ends that do not have the bolt connectors (front side).



B-Body Connector

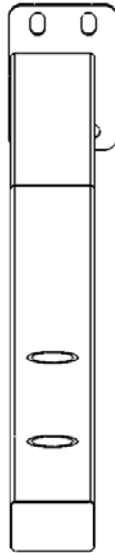

DRIVER SIDE

E-Body Connector

E-BODY CONNECTORS ARE SYMMETRICAL

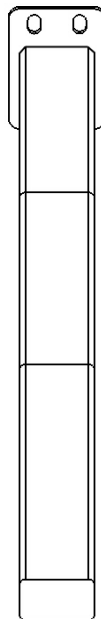

3. Remove Nuts from Frame

Temporarily support the rear subframe with jacks to relieve the load on the leaf springs. Do not jack up the car too much or else the weight of the rear end and wheels will hang in the air and cause the front mount to pull downward. Remove the 4 nuts on the front leaf spring mounts.



3b. Torque Box Vehicles ONLY!

Some vehicles have torque boxes which may cover the path of the subframe connectors. *If you car does not have torque boxes, then you can proceed to step 4.* You will need to cut the forward section of the torque box so the subframe connector can mount flush to the floor pan.



In addition, you will notice it will be extremely difficult to access the leaf spring mount nuts once the subframe connector is in place. To alleviate this problem, you will need to weld bolts onto the subframe connectors so you can fasten everything from the rearward side of the mount. Procedure to follow...

Steps:

- Remove the front leaf spring mounts from each leaf spring
- Remove the 4 studs that are pressed in the mount (If you are installing Hotchkis leaf springs, then you will be able to use the Hotchkis mount instead)

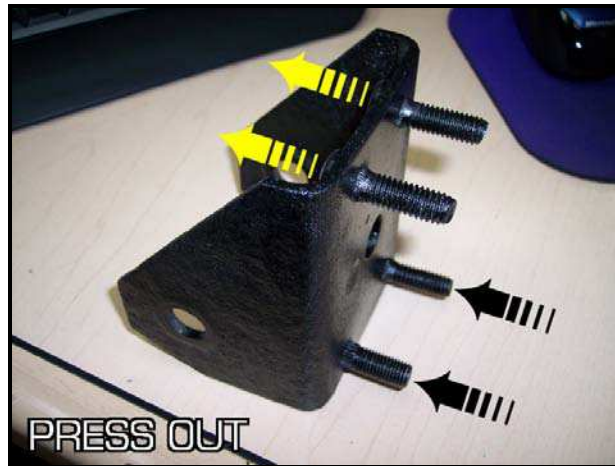

- Mock up the leaf spring bracket and the subframe connectors to get proper bolt locations. This will require the following from your local hardware store:

- Grade 8 - 3/8" - 24 x 1.5 hex bolts (qty.8)
- Grade 8 - 3/8" SAE washers (qty. 16)
- Grade 8 - 3/8" - 24 nylock nuts (qty.8)



Mock-up shown with Hotchkis leaf spring mount

- FYI--The aforementioned hardware is included with the Hotchkis leaf spring kit.

- Weld the bolt and washer to the subframe connectors. Disassemble the mock-up.



- Reinstall the leaf spring mount and continue with the subframe connector installation.

4. Connect Subframe

Slide the rear of the subframe connector onto the 4 bolts that you just removed the nuts from. Once subframe is on, replace the nuts and snugly tighten, but not fully tighten.

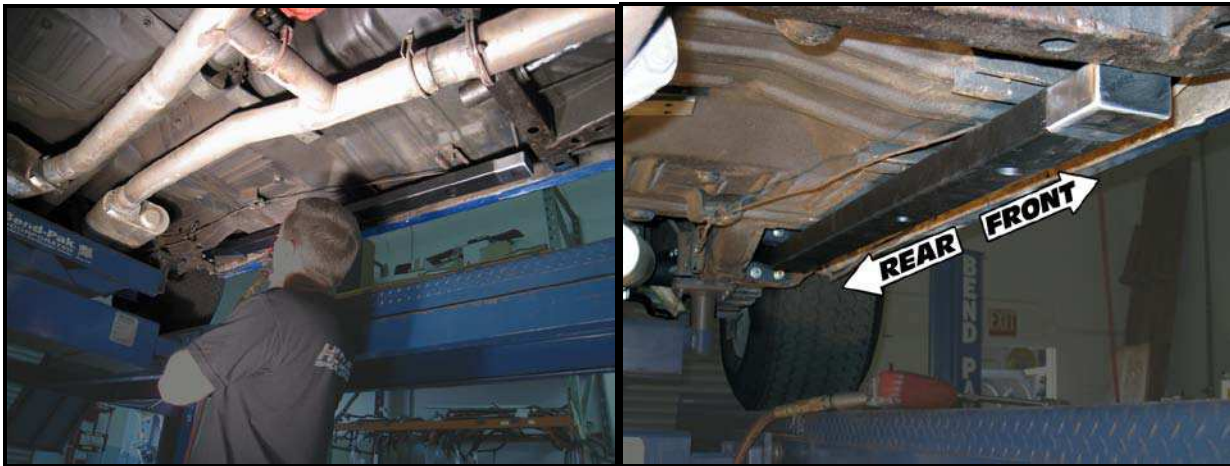

5. Position the Subframe

Using a screw jack to hold the subframe up and in place, mark the area where you will be attaching the front mounting bracket and then remove both the mounting bracket and subframe.

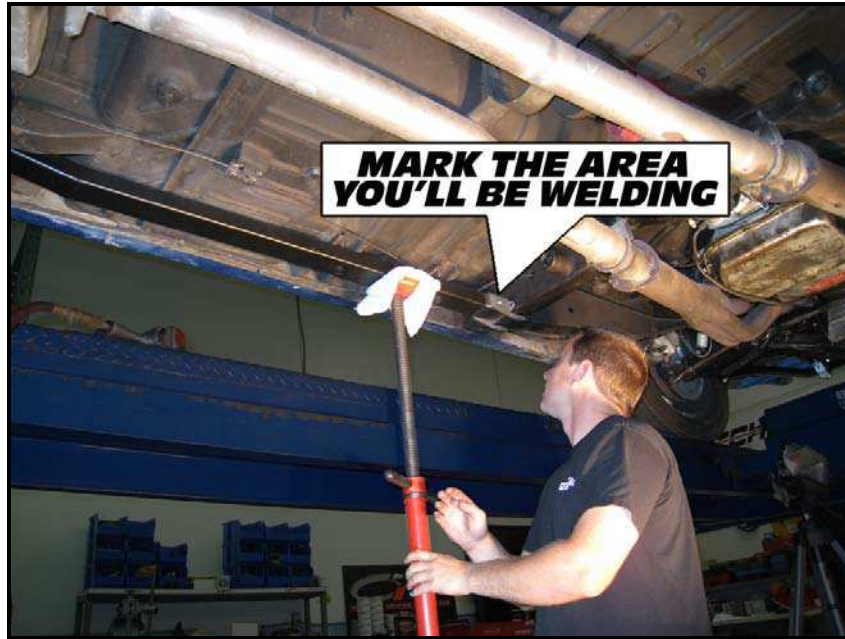

6. Seat Mounting Bolts

Be sure the seat mounting bolts line up with the seat mounting bolts access holes that are on the subframe before moving on.

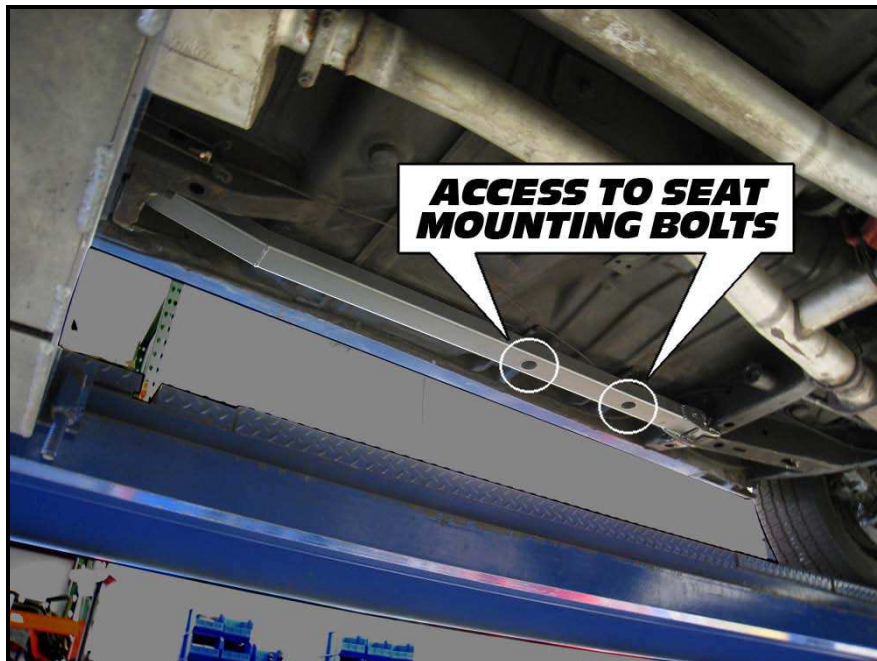

7. Prepare Frame for Welding

After you remove the mounting bracket and subframe connector, sand down the area of the frame where you will be welding.



8. Spot Weld Mounting Bracket

Install the subframe connector again with the mounting bracket resting in place on top. Be sure to use the screw jack to hold the subframe in place. Spot weld the mounting bracket and then once again, remove the subframe connector.

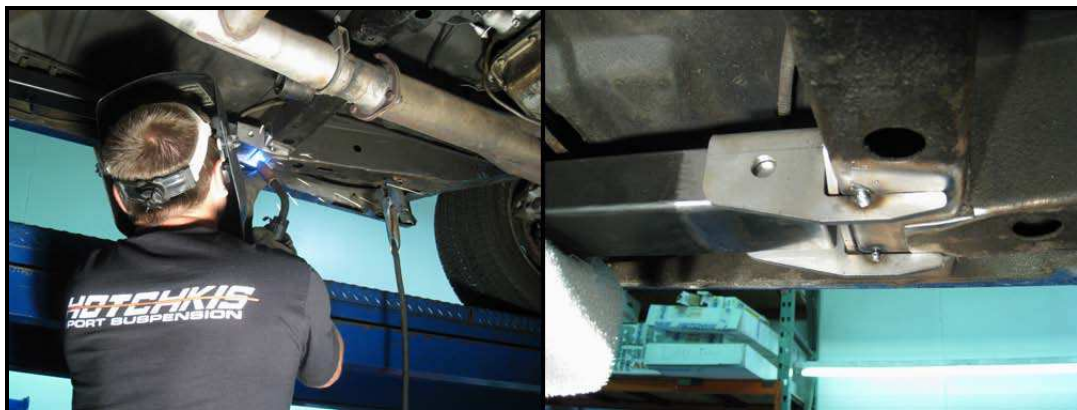

9. Clean Surface / Weld Mounting Bracket / Install Subframe / Weld Subframe

Before welding, be sure that all of the surfaces that you will be welding is clean. Weld the front mounting bracket to the frame.

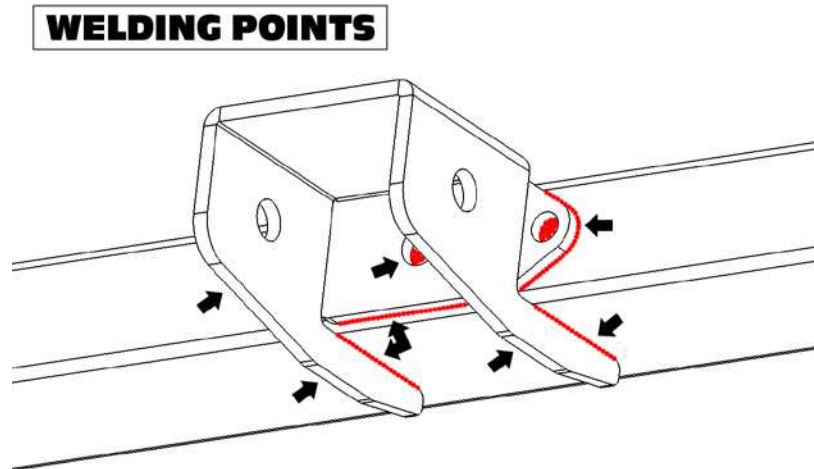

When you're done welding the front mounting bracket, reinstall the subframe connector. Fully tighten the 4 rear mount nuts. You may now remove the jacks supporting the rear subframe. The full weight of the car should be on all four tires from now on. Use the screw jack once again to hold the subframe in place if need be. Now weld the subframe connector to the front mounting bracket.

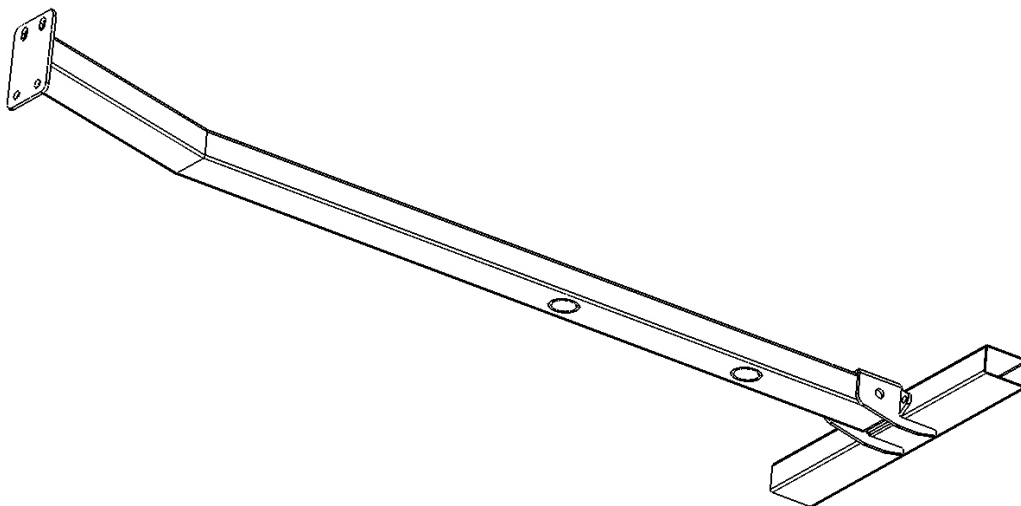

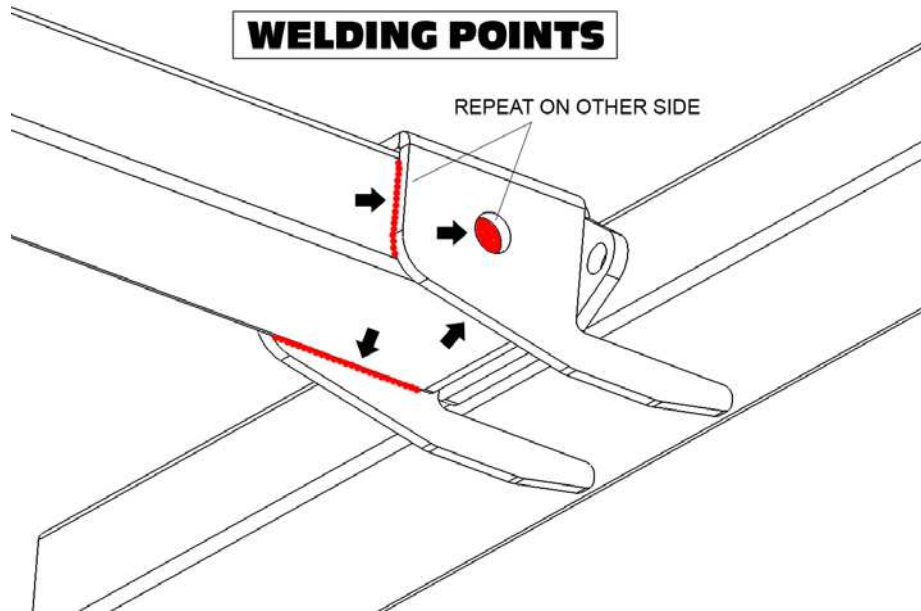

10. Paint

After the metal has cooled down, paint all exposed raw surfaces with a rust resistant paint.



11. Repeat & Finished

Repeat steps 1-10 to install the passenger side subframe and you're all set.

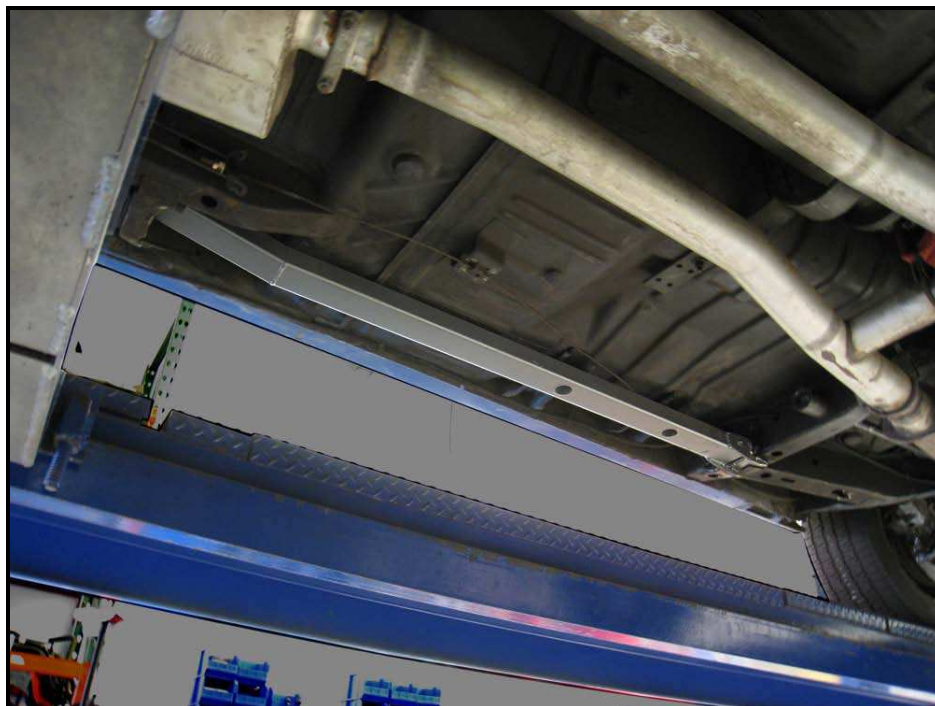



Hotchkis Performance LLC Return Policy & Limited Warranty

Effective December 1, 2010 all Hotchkis products must be registered to qualify for warranty at www.hotchkis.net or via the mail-in warranty card, included with the product, within 30 days of the original purchase date.

IMPORTANT: This warranty supersedes all other warranties included with this product.

Return Policy

We want you to be completely satisfied with your Hotchkis Performance product. For products, presenting signs of shipping damage please contact the freight carrier immediately. All our products are guaranteed to be free from manufacturer's defects. If your order arrives with a manufacture defect, please contact our Customer Service Department at (562) 907-7757. You will be assigned a Returned Goods Authorization Number (RGA). The package you return must show the RGA on the outside of the package, include the original invoice and be shipped prepaid to our facility. The product has to be unused and in its original packaging materials. Exchanges or refunds made after 30 days will be subject to a 20% restocking charge. **If you purchased your Hotchkis Performance product from an authorized dealer, you are still covered by this return policy. All returns however, should be made to your dealer, not to Hotchkis Performance directly.**

Limited Warranty

Hotchkis Performance offers a Limited Warranty against defects in materials and workmanship for the term of 36 months (3 years) from the date of purchase of this product. This Warranty only applies to the original retail purchaser who retains ownership of the vehicle on which the product was originally installed. If the product is determined to be defective, Hotchkis Performance will repair, replace or refund the purchase price of the defective product at Hotchkis Performance's sole discretion, which shall fully satisfy and discharge any and all warranty claims. Any repaired or replaced product will be returned to the sender excluding the cost of freight. **Products**

must be registered to qualify for warranty at www.hotchkis.net or via the mail-in warranty card, included with the product, within 30 days of the original purchase date.

Exclusions from Warranty

Items offered but not manufactured by Hotchkis Performance are warranted according to the manufacturer's terms and are not covered by this limited warranty. Hotchkis Performance shall not be responsible for any labor, removal, installation, re-installation or maintenance costs. This warranty does not cover the cosmetic finish or plating of any product or any normal wear and tear to any product including, but not limited to bushings, brackets, end-links, hardware, steering components, shocks or springs. In addition, this warranty does not apply to any products that have been:

- **Improperly installed or installed by someone other than a qualified, licensed auto mechanic experienced in the installation and removal of suspension products;**
- **Improperly serviced, misused, or modified, altered or subjected to abuse, negligence, accident or collision;**
- **Installed in any vehicle that has been modified;**
- **Installed on any vehicle that has carried loads in excess of automobile manufacturer suggested weight limits; or**
- **Installed on any vehicle that has been subject to abnormal or excessive use, including rallying, racing, or racing-type activities or off-road use.**

Limitation of Warranty

This limited warranty is the entire and only warranty for the products and may not be modified or supplemented by any other person or company in any form. Any description of the products, by anyone, is for the sole purpose of identifying them and is not part of the basis of the bargain, and does not constitute a warranty that the products will conform to that description. The statements of any salesperson do not constitute part of this limited warranty and cannot be relied upon as a warranty.

THERE ARE NO WARRANTIES, EXPRESSED OR IMPLIED, INCLUDING ANY IMPLIED WARRANTIES OF MERCHANTABILITY OR FITNESS FOR A PARTICULAR PURPOSE, WHICH EXTEND BEYOND THE DESCRIPTION ON THE FACE HEREOF. ANY IMPLIED WARRANTIES ARE DISCLAIMED TO THE FULLEST EXTENT PERMITTED BY LAW. THIS WARRANTY DOES NOT COVER CONSEQUENTIAL DAMAGES, LOSS OF TIME OR REVENUES, INCONVENIENCE, LOSS OF USE OF THE VEHICLE, DAMAGE TO THE VEHICLE OR COMPONENTS OF THE VEHICLE, ANY OTHER TYPE OF CONSEQUENTIAL DAMAGES, OR OTHER INCIDENTAL OR INDIRECT DAMAGES. HOTCHKIS' MAXIMUM LIABILITY UNDER THIS WARRANTY SHALL IN NO EVENT EXCEED THE PURCHASE PRICE OF THE PRODUCT. Some states do not allow limitations on how long an implied warranty lasts or the exclusion or limitation of incidental or consequential damages and in such states the above limitations or exclusions may not apply. This limited warranty gives the purchaser specific legal rights and the purchaser may have other rights that may vary from state to state.

Technical Information

Hotchkis Performance makes every effort to ensure that you are provided with the most accurate and up-to-date technical information. However, all technical information is approximate and may vary upon application. Additional suspension components may be needed in some applications, depending upon the make, model, engine and chassis of the vehicle. Hotchkis Performance is not responsible for any consequences resulting from manufacturer's technical mid-year changes. Hotchkis Performance products should only be installed by a qualified, licensed auto mechanic experienced in the installation of such products.

Warranty Claim Procedure:

The answer to ALL the following questions should be YES before making a warranty claim:

- Did you register the product at www.hotchkis.net or via the mail-in warranty card within 30 days of purchase?
- Is the product appropriate to your application?
- Did you carefully and thoroughly read the instructions provided along with the product?
- Do you have the original invoice or sales receipt?
- Is the return date within 36 months from the purchase date?
- Are you the original purchaser?
- Was the product properly installed by a qualified, licensed auto mechanic?
- Has the product been installed on the original vehicle on which it was installed at all times?
- Is the product unmodified and clean?
- Is the reason for return a legitimate product defect?

If the answer to all these questions is YES, please contact our Customer Service Department at (562) 907-7757. You will be given a Returned Goods Authorization Number (RGA) valid for 60 days. You will also be asked to ship the product prepaid to our facility. All shipments MUST be (i) prepaid, (ii) include the original invoice or sales receipt, (iii) show the RGA on the outside of the package and (iv) include your name, address, make and model of the vehicle, and a brief description of the claimed defect, including the circumstances under which the defect occurred. If the warranty claim is deemed valid then Hotchkis will estimate shipping costs to return the repaired or replacement part and contact you for payment. Hotchkis's Limited warranty requires that any repaired or replaced product will be returned to the sender excluding the cost of freight. Warranty related inquires should be sent to the following address:

**HOTCHKIS PERFORMANCE, LLC
C/O CUSTOMER SERVICE
8633 Sorensen Avenue
SANTA FE SPRINGS, CA 90670**

Hotchkis Performance will not accept product returns without the RGA number, receipt and the information described above. C.O.D. or collect shipments will be refused. Once the returns are received at Hotchkis Performance, we will evaluate the products, verify the sales receipt, and investigate the warranty claim. Any repaired or replaced product will be returned to the sender.

**Effective December 1, 2010. This return policy and limited warranty supersedes all previous policy and warranty statements. Policies and warranties are subject to change without notice.
Hotchkis Performance is not responsible for printing errors.**

