



INTAKE SYSTEMS FOR VEHICLES LISTED ARE 50 STATE LEGAL. SEE KNFILTERS.COM FOR CARB STATUS ON EACH PART FOR A SPECIFIC VEHICLE.

INSTALLATION INSTRUCTIONS

57-1568
RAM
2013-15 2500 / 3500
L6-6.7L Diesel

NOTE: This kit was not designed to fit vehicles with a body lift.

TOOLS NEEDED:

- flat blade screw driver
- 13mm socket
- 5/16 socket
- ratchet
- extension

PARTS LIST:

Description	Qty.	Part #
A INTAKE TUBE	1	087276
B HOSE CLAMP # 72	2	08671
C HOSE; 4-1/2" ID X 3"L HUMPH	1	08695
D AIR FILTER	1	33-5005

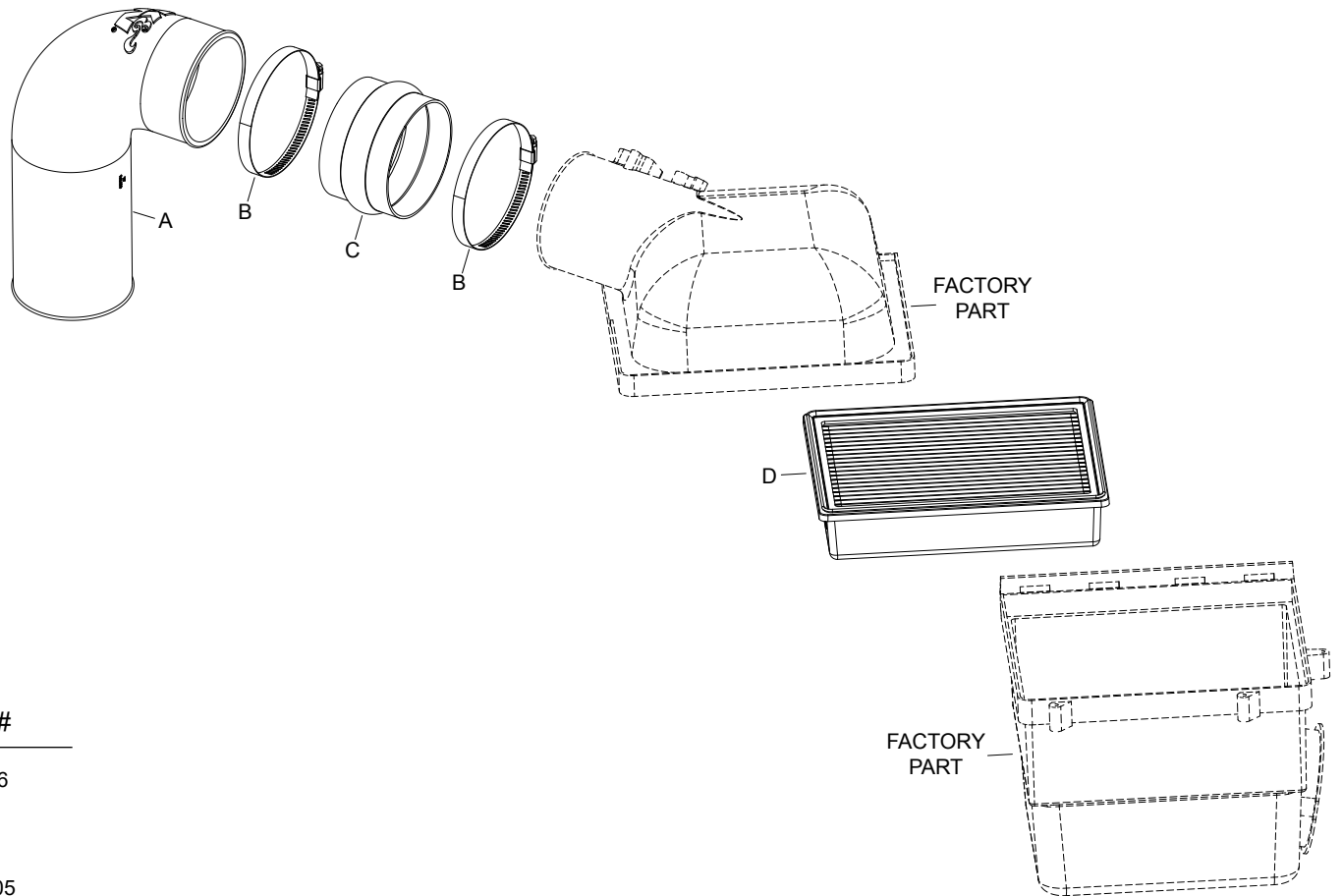

If you need any assistance please call 1-800-858-3333 to speak with a representative in our Customer Service Center before returning the product.

NOTE: FAILURE TO FOLLOW INSTALLATION INSTRUCTIONS AND NOT USING THE PROVIDED HARDWARE MAY DAMAGE THE INTAKE TUBE, THROTTLE BODY AND ENGINE.

TO START:

1. Turn off the ignition and disconnect the negative battery cable.
NOTE: Disconnecting the negative battery cable erases pre-programmed electronic memories. Write down all memory settings before disconnecting the negative battery cable. Some radios will require an anti-theft code to be entered after the battery is reconnected. The anti-theft code is typically supplied with your owner's manual. In the event your vehicles anti-theft code cannot be recovered, contact an authorized dealership to obtain your vehicles anti-theft code.



2. Disconnect mass air sensor and temperature sensor electrical connections, then unhook the wiring harness from air box.



3. Loosen the hose clamp securing the intake resonator to turbo inlet hose.



4. Remove the three screws securing air box lid.



5. Remove air box lid and intake resonator from the vehicle.

NOTE: K&N Engineering, Inc., recommends that customers do not discard factory air intake.



6. Remove filter from air box base.



7. Install K&N® filter into air box base.



8. Loosen hose clamp securing intake resonator to air box lid and remove intake resonator from lid.



9. Reinstall air box lid onto air box base.



10. Install coupling hose (08695) onto air box assembly. Secure with provided hose clamp.



11. Install K&N® intake tube into the factory turbo inlet hose and then into coupling hose (08695). Secure K&N® intake tube with provided hose clamps.



12. Reconnect the mass air sensor and temperature sensor electrical connections.



13. Reconnect the vehicle's negative battery cable. Double check to make sure everything is tight and properly positioned before starting the vehicle.

14. The C.A.R.B. exemption sticker, (attached), must be visible under the hood so that an emissions inspector can see it when the vehicle is required to be tested for emissions. California requires testing every two years, other states may vary.

15. It will be necessary for all K&N® high flow intake systems to be checked periodically for realignment, clearance and tightening of all connections. Failure to follow the above instructions or proper maintenance may void warranty.

ROAD TESTING:

1. Start the engine with the transmission in neutral or park, and the parking brake engaged. Listen for air leaks or odd noises. For air leaks secure hoses and connections. For odd noises, find cause and repair before proceeding. This kit will function identically to the factory system except for being louder and much more responsive.

2. Test drive the vehicle. Listen for odd noises or rattles and fix as necessary.

3. If road test is fine, you can now enjoy the added power and performance from your kit.

4. K&N Engineering, Inc., requires cleaning the intake system's air filter element every 100,000 miles. When used in dusty or off-road environments, our filters will require cleaning more often. We recommend that you visually inspect your filter once every 25,000 miles to determine if the screen is still visible. When the screen is no longer visible some place on the filter element, it is time to clean it. To clean and re-oil, purchase our filter Recharger® service kit, part number 99-5050 or 99-5000 and follow the easy instructions.

INTAKE SYSTEMS FOR VEHICLES LISTED ARE 50 STATE LEGAL. SEE KNFILTERS.COM FOR CARB STATUS ON EACH PART FOR A SPECIFIC VEHICLE.