



985xx Replacement Top with Zip Out Rear panels for: 86-94 Suzuki Samurai

Getting started:

IMPORTANT: You should first try to pick a warm day above 70 degrees to install the top. Remove it from the box and lay it out in the sun on a soft surface to allow it to soften up and be more flexible during installation.

Included:

Replacement top panels	2 x 10-24 screw
Strap set	2 x 10-24 nut
5 x Snaps	Hook & loop strips

Tools required:

3/32" drill bit	Philips screw driver
7/32" drill bit	
Drill body	

Installation

Step 1

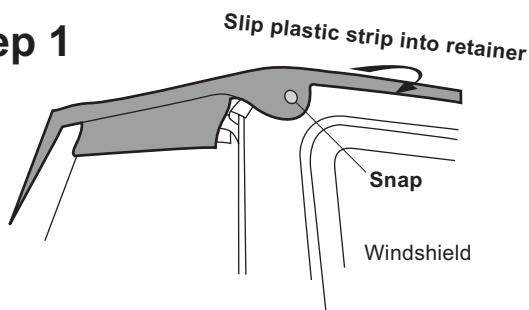

Lay the main skin out on the vehicle and insert the plastic strip into the channel over the front windshield. Now snap the front two snaps. Open the hook and loop flap on the sides over the front doors

Step 2

Drape the top over the rear bow and be sure to tuck the bow up into the rear corners as far as possible.

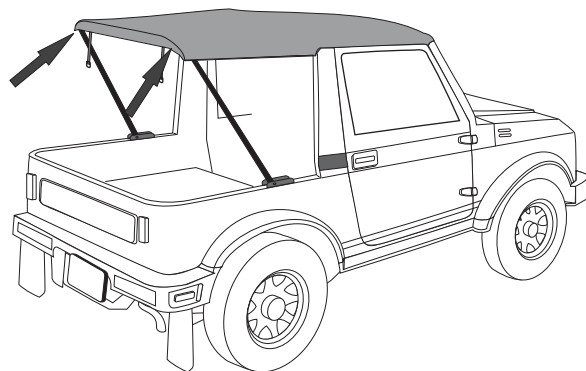

Step 3

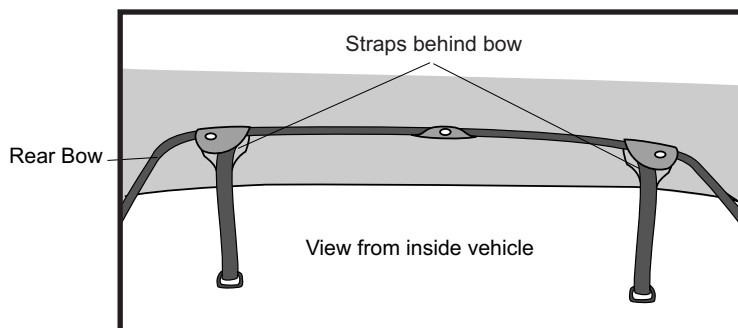

Make sure that the straps sewn into the rear of the top are behind the rear bow.

Step 4

Install the tension strap through the loop on the strap sewn into the top. Pull tight and secure with hook and loop.

NOTE: If the straps are damaged or missing from your vehicle use the included hardware to replace it.

NOTE: Do not over tighten the strap as it may damage the loop or the strap.

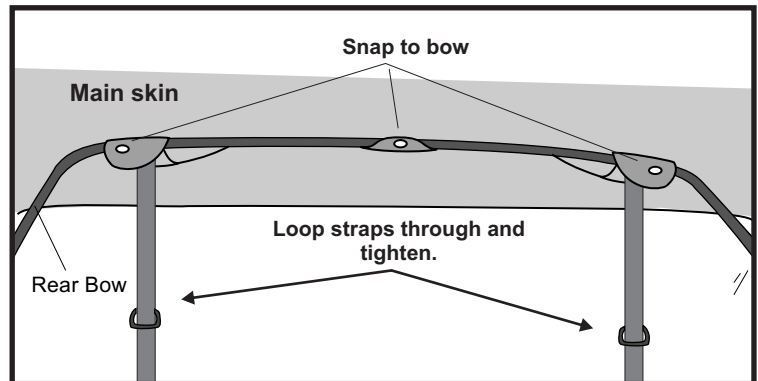

Step 5

Snap the top to the bow. Be sure to wrap the outer flaps around the front of the bow and the center from the rear.

NOTE: If the studs are missing from the bow use the included snaps to replace them.

Step 6

Wrap flaps around door frames and attach hook strips to loop strips.

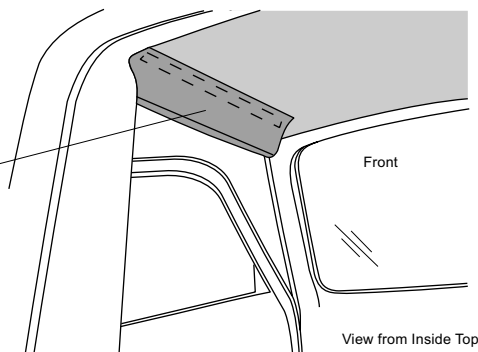

Step 7

A) Fold back the corner of the main skin where the side window needs to be inserted into the channel.

B) Insert the side window bead into the channel.
NOTE: Be careful not to let the side panel hook on the sheet metal of the channel, it may rip the top if forced.

C) Once the side panel is inserted all the way, start the zipper at the front corner and zip to the rear.

D) Now snap the snaps along the lower edge of the side panel.

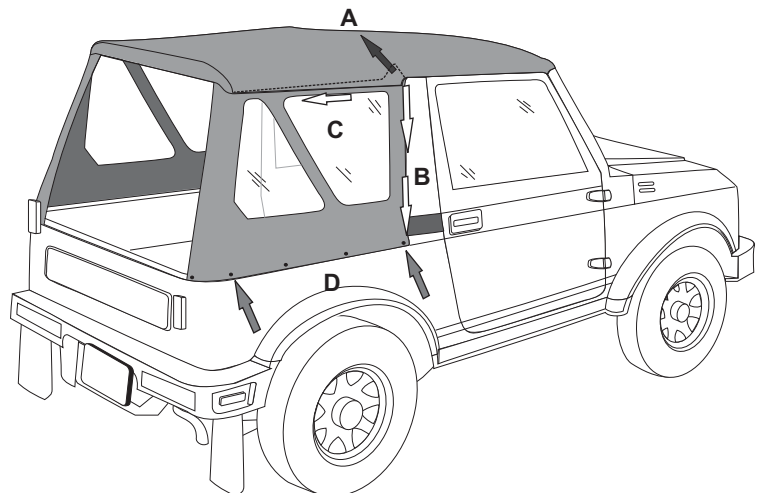

Step 7

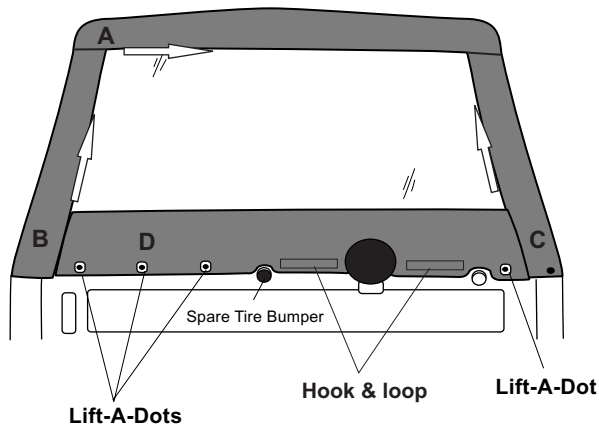

A) Start with the top zipper on the upper right side of the vehicle and zip in the rear window.

B) Now start the lower right zipper. Only zip up a short distance to allow the final zipper more slack to start.

C) Finish with the right side zipper. Now zip up both sides.

D) Now snap the snaps along the bottom of the rear panel and attach hook and loop.

NOTE: If your vehicle does not have the hook and loop, use the provided adhesive backed pieces to install on the rear door of the vehicle. Align with the strips on the rear window for placement.

NOTE: It may be necessary to adjust the tension on the rear bow straps to get proper fit on the top. If the rear panel is too loose, then loosen the straps slightly. If the top is very difficult to install try tightening the straps.

Rear Curtain

To roll up the Rear Curtain, start at the bottom and roll it to the inside. Avoid wrinkles in the fabric and window. Secure it in place with the curtain straps inside of the top.

Warning: Do not operate the vehicle with the rear window rolled up unless a side window is open also for ventilation

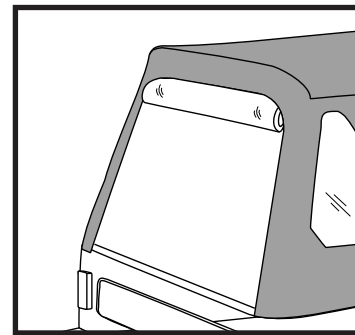

Important Care Instructions:

Convertible tops and accessories require special care if you want to get the maximum usage and enjoyment from them. The following recommendations, if followed carefully, can extend the life of your top or accessory.

Hand wash using a mild non-detergent soap such as ivory. Use a non-abrasive cloth or sponge. Rinse thoroughly.

Do not wash in direct sunlight and avoid automatic car washes

When your top is clean, we recommend using "Ragg Topp" or "303 Protectant" on both the vinyl top and windows. This product contains a sunscreen that helps protect from the sun's damaging rays. Stay away from products containing alcohol, as it will cause the fabric and windows to lose their elasticity, thus reducing the life of your top or accessory. If you are unable to locate "RaggTopp" Please call 1-800-377-4700 for a distributor near you. For "303 Protectant", please call 1-800-223-4303 for a distributor near you.

Direct sunlight and heat are the biggest enemies of the windows. Park in the shade whenever possible. If you must park in the sunlight, rotate the direction that you park every few days so all windows get even exposure.

Our tops are designed so that you may roll up and/or store the rear curtain and side curtains. To prevent scratching of the windows, be sure that windows are completely clean and free of dust particles. Even a little dirt will badly scratch the windows. You may want to use a soft cloth when rolling up or storing your windows. Heat may build up on rolled up windows, so be sure to unroll them frequently. If you roll up the windows at the beginning of summer and leave them, they may be ruined by fall.

Do not open or roll up windows at temperatures below 45 degrees F this could cause them to crack or break.

Warranty Information

Rampage products, Inc. warrants to the original purchaser of any top it manufactures, that the top will be free of defects in material or workmanship for a period of 1 year from date of purchase. Such obligations under this warranty shall be limited to the repair or replacement, at Rampage products discretion, of any assembly or parts which, upon examination by Rampage products, Inc. proves to be defective. All defective items must be returned with proof of purchase to Rampage products, Inc., freight prepaid. This warranty does not cover damage resulting from abuse, misuse, alteration, accident or damage in transit. Rampage products obligations under this warranty are limited to the aforementioned repair or replacement of warranty defects for which the return authorization has been received during the warranty period, and Rampage products, Inc. shall not be liable for any incidental or consequential damages arising from breach of this or any implied warranty.

Rampage Products 22420 Temescal Canyon Rd. "C", Corona, CA 92883 Phone: (951) 277-4949 Fax: (951) 277-2295

www.rampageproducts.com

Made in China