



In Channel **SNAP/INZ**TM Sidewind Deflectors

INSTALLATION INSTRUCTIONS

WARNING: Improper installation can result in damage to the sidewind and/or window/window mechanisms.

BEFORE INSTALLATION:

- Trial fit the Sidewind Deflector to vehicle to ensure fit. Take note of where the adhesive will make contact.
- Clean window channels with glass cleaner. Allow cleaner to dry completely.
- Wipe the area where the adhesive strip will contact the window channel gasket with the alcohol pad provided. Allow the alcohol to dry completely.
- Apply the adhesive promoter to the areas where the adhesive will make contact, and allow to dry.

- 1** Install the metal clip to the rear of the window frame. Pull back the exterior weather strip at approximately 2 inches below the top rear corner of the window frame to expose the metal underneath (fig A). Slide the short side of the clip onto the metal edge of the frame just above the hole (fig B). Insert the weather strip into the larger side of the the metal clip (fig C).

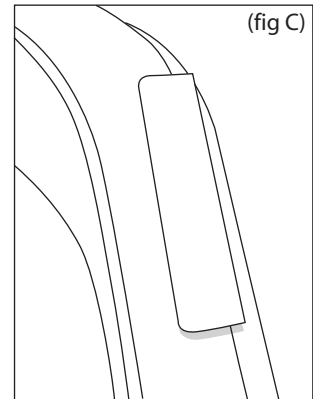
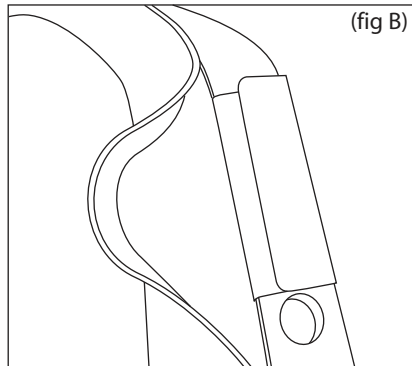
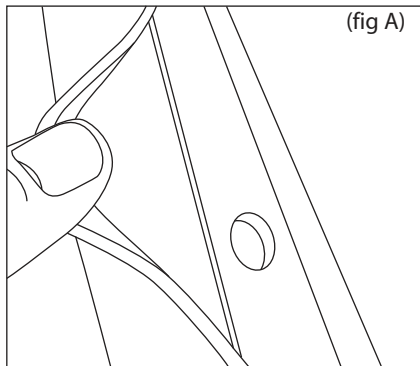

- 2** Remove the red backing from the adhesive. Insert the vertical leading edge of the sidewind into the channel behind the mirror assembly. (fig 1) Insure the adhesive strip on the tab on the bottom of the sidewind is securely fastened to the **OUTSIDE** of the flexible weatherstripping. (fig 2)

- 3** While holding the front end of the sidewind into the channel with one hand, continue inserting the flange on the top of the sidewind into the channel, ending up at the top rear corner of the window frame. (fig 3) When you reach the rear corner of the window frame slightly bend the sidewind and slide the tab into the metal clip and push upwards ensuring that the top flange is securely seated into the window channel (fig 4).

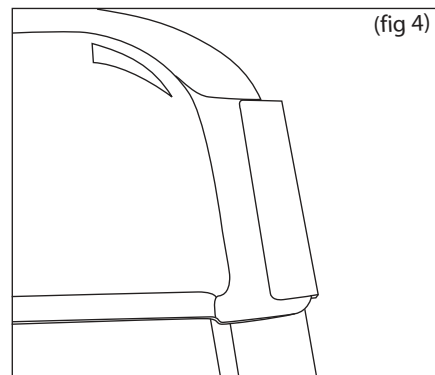
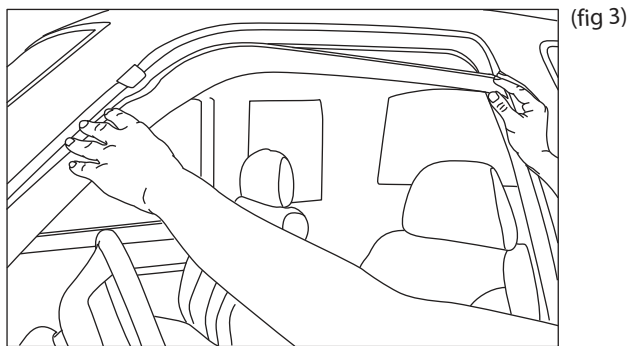
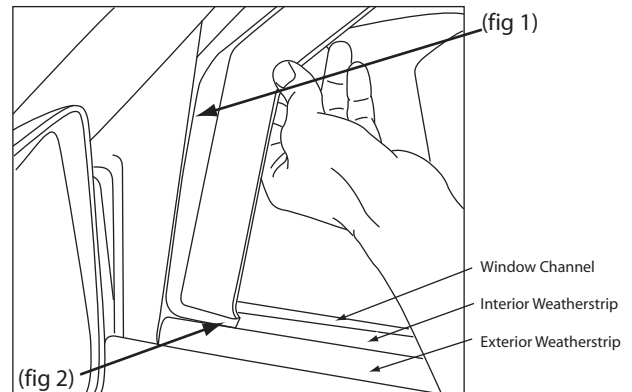

- 4** Carefully open and close the window several times to insure that the top flange on the sidewind is firmly and securely seated into the channel. Leave the window closed for at least 24 hours for best results.

Repeat steps for passenger side window.