

IMPORTANT: READ BEFORE INSTALLATION

STEP 1: REMOVE FACTORY FENDER FLARES, FENDER TRIM AND MUD FLAPS IF INSTALLED.

STEP 2: VERIFY FIT

(A) FLARES SHOULD BE HELD TO VEHICLE TO VERIFY CORRECT TYPE AND FIT BEFORE BEGINNING INSTALLATION.

STEP 3: PAINTING (OPTIONAL)

(IF PAINTING IS DESIRED IT IS RECOMMENDED TO BE DONE PRIOR TO INSTALLATION.)

PAINTED FLARES CANNOT BE RETURNED. TEST FIT BEFORE PAINTING

- (A) SAND (OPTIONAL) BEFORE APPLICATION OF PAINT
- (B) CLEAN OUTER SURFACE WITH A WAX & GREASE REMOVER *(DO NOT USE LACQUER THINNER OR ENAMEL REDUCER AS A DEGREASER)*
- (C) WIPE OUTER SURFACE WITH A TACK CLOTH.
- (D) PAINT FLARES USING A HIGH QUALITY LACQUER, ENAMEL, OR POLYURETHANE AUTOMOTIVE PAINT. *(APPLICATION OF A PRIMER COAT PRIOR TO PAINTING IS OPTIONAL)*
- (E) IF PAINTING EDGE TRIM (NOT RECOMMENDED) USE A FLEX ADDITIVE.

STEP 4: EDGE TRIM INSTALLATION

- (A) PEEL THREE INCHES OF RED BACKING AWAY FROM EDGE TRIM ADHESIVE AND AFFIX TO OUTER EDGE OF FLARE AT ONE END.
- (B) PRESS EDGE TRIM INTO PLACE ALONG EDGE OF FLARE IN ONE-FOOT INCREMENTS, PULLING RED BACKING FREE AS YOU CONTINUE TO WORK YOUR WAY AROUND THE FLARE. (Fig 1)

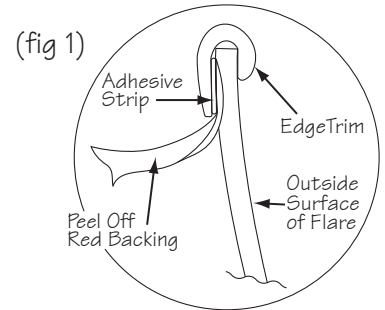

(STEP 5 APPLIES ONLY TO "Ruff Riderz" STYLE FLARES, FOR ALL OTHERS, SKIP TO STEP 6)

STEP 5: BOLT INSTALLATION

- (A) DRILL A 5/16" HOLE IN THROUGH THE DIVITS IN EACH OF THE POCKETS
- (B) PLACE A 5/16" BUTTON HEAD SCREW WITH A WASHER INTO EACH OF THE HOLES AND ATTACH TO THE FLARE USING A NUT PLACED ON THE INSIDE. (fig 2)

WARNING: DO NOT OVER TIGHTEN OR USE LOCTITE® ON THE BOLTS AS THIS WILL CAUSE PERMANENT DAMAGE TO THE FLARES. BOLTS ARE DECORATIVE ONLY AND FASTEN ONLY TO THE FLARES. DO NOT ATTEMPT TO USE THE BOLTS TO FASTEN THE FLARES TO THE VEHICLE.

STEP 6: FRONT FLARE INSTALLATION

- (A) REMOVE THE 4 FACTORY SCREWS HOLDING THE PLASTIC INNER FENDER WELL TO THE FENDER AND SET ASIDE.
- (B) USING THE REMOVED FACTORY SCREWS, ATTACH THE MOUNTING BRACKETS TO THE INSIDE OF THE FENDER.
- (C) ADJUST BRACKET SO THAT THE EDGE OF THE BRACKET IS EVEN WITH THE EDGE OF THE FENDER AND TIGHTEN. (fig 3)
- (D) SLIDE THE "U" CLIP OVER THE SQUARE HOLE IN THE BRACKET. (fig 4)
- (E) HOLD THE FLARE IN PLACE ON THE VEHICLE AND LINE UP THE HOLES ON THE FLARE WITH THE HOLES OF THE MOUNTING BRACKETS AND FACTORY HOLES ON THE VEHICLE FENDER. RE-USE THE FACTORY SCREWS AND SCREWS FROM THE HARDWARE PACK TO SECURELY MOUNT THE FLARE TO THE VEHICLE.

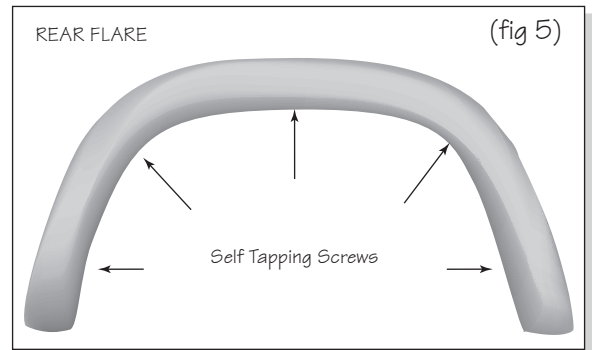
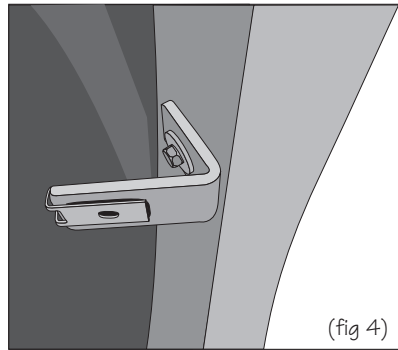
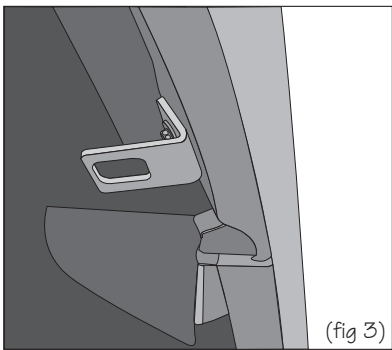
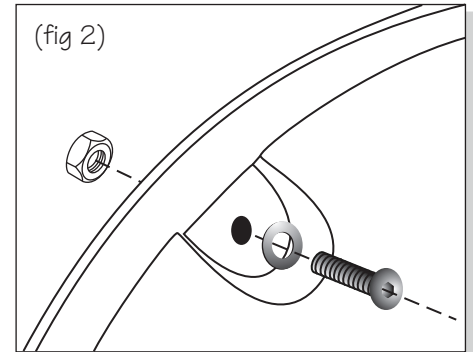

STEP 7: REAR FLARE INSTALLATION

- (A) HOLD FLARE IN PLACE ON FENDER.
- (B) APPLYING MODERATE PRESSURE TO OUTSIDE SURFACE OF FLARE, FASTEN WITH THE SELF TAPPING SCREWS INTO THE SHEET METAL LIP THROUGH THE PRE-DRILLED HOLES IN THE FLARE. (fig 5)