



Tape On Style Window Vents



Part Numbers: 2xxx & 4xxx series



30-60 min



CUTTING NOT
REQUIRED



DRILLING NOT
REQUIRED



REMOVE CONTENTS FROM BOX. VERIFY ALL PARTS ARE PRESENT.



READ INSTRUCTIONS CAREFULLY BEFORE STARTING INSTALLATION.

Important Safety Information

- **CAUTION** - Before driving, ensure that the wind deflector is properly secured to vehicle.
- Do not use automatic "brush-style" car washes.
- Do not use cleaning solvents of any kind.
- Periodically check all components for tightness.

Contents - 2 Piece Set

NOTE: Actual product may vary from illustration.



Front Driver
Side Visor



Front Passenger
Side Visor



Alcohol
Pad x2

Contents - 4 Piece Set



Front Driver
Side Visor



Front Passenger
Side Visor

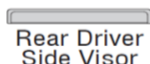

Rear Driver
Side Visor

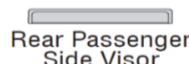

Rear Passenger
Side Visor



Alcohol
Pad x4

Tools Required





Putty Knife

Preparation Before Painting / Installation

- A trial fit is recommended to ensure proper positioning and fit.
- Check fit of parts before painting as we will not accept the return of modified or painted parts.
- Wash your vehicle to remove any debris and/or dirt.
- Dry with a clean towel.

INSTALLATION STEPS

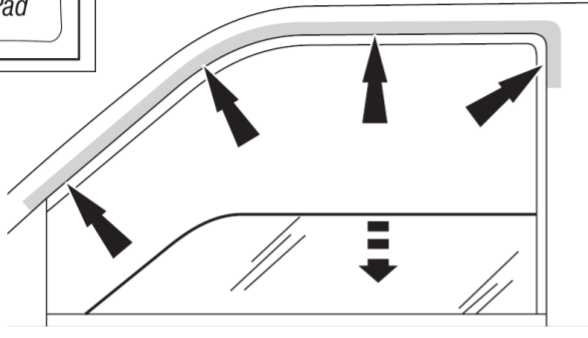
NOTE: Actual application may vary slightly from illustrations.

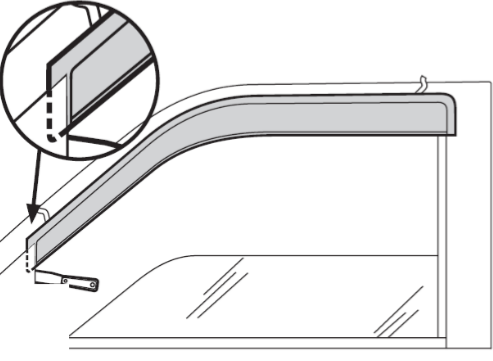
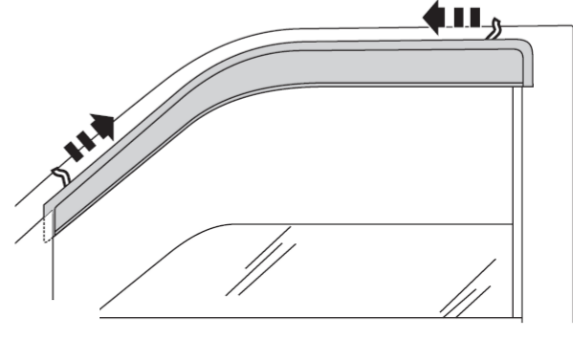
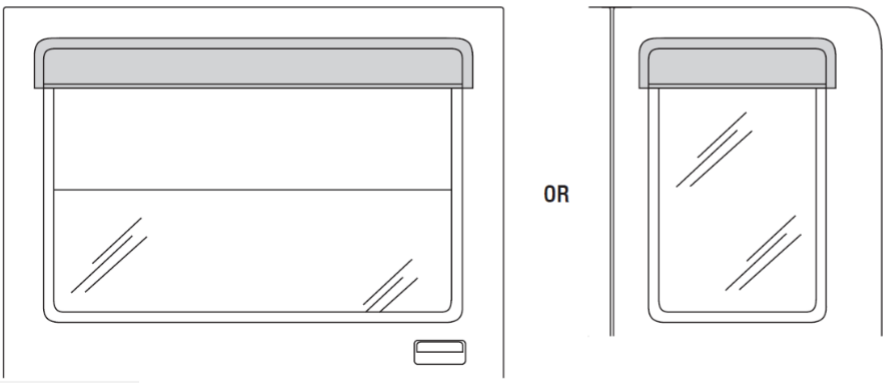
<div data-bbox="95 257 271 436"><p>Alcohol Pad</p></div> <div data-bbox="694 257 798 358"><p>1</p></div>  <p>Lower the window. Clean the door's painted surface where the visor will attach.</p>	<div data-bbox="1404 257 1508 358"><p>2</p></div>  <p>Remove the tape liner from the rear flange. Peel back 2" of tape liner from each end of top flange.</p>
<div data-bbox="694 817 798 918"><p>3</p></div>  <p>Slide the front flange behind the mirror cap, use a putty knife to create a gap if needed. Attach the top and rear flanges to the door's painted surface.</p>	<div data-bbox="1404 817 1508 918"><p>4</p></div>  <p>Remove tape liner by pulling on free ends. Apply pressure to top and rear tape flanges to secure. Raise the window.</p>
<div data-bbox="95 1344 271 1388"><p>4 Piece Set</p></div> <div data-bbox="1404 1310 1508 1411"><p>5</p></div>  <p>The rear visor attaches with same preparation methods as the front visor. Attach visor to the vehicle's painted surface.</p>	

PRODUCT CARE

- Periodically check the product to ensure all fasteners are tight and components are intact.
- Regular waxing is recommended to protect the finish of the product.
- **Use ONLY Non-Abrasive automotive wax.** Use of any soap, polish or wax that contains an abrasive is detrimental and Can scratch the finish leading to corrosion.
- Aluminum polish may be used to polish small scratches and scuffs for **Stainless Steel finish.**
- Mild soap may be used to clean the product for both **Stainless Steel and Black finish.**

FAQ's

1. **Hardware's are not of correct size.**
In GMC / Chevrolet truck model 2006 & up, customer needs to reuse the factory body bolts to install the bracket. If your vehicle is not GMC / Chevrolet 2006 & up, please ensure that holes are not partially covered with any plastic grommet or rust? If it is, please remove the plastic grommet & rust from the thread holes & re-try the installation.
2. **Mounting Bracket are not getting Installed properly.**
In some cases Illustration images shown in Installation manual may not be the exactly same as per actual vehicle images ,also if Driver / Passenger side mounting brackets are very identical in the design, suggest referring Parts Identification guide to avoid fitment issue.
3. **Products are thumping / rattling after installation.**
Please ensure that all required mounting brackets / hardware's are installed & tighten correctly. Suggest using white lithium / regular grease between the metal to metal contact surfaces.
4. **Side Bar is not aligning with vehicle / Step Pads are not aligning with vehicle doors.**
Side bar may be interchanged or mounting brackets are not installed at the correct position in the vehicle. Please refer Parts identification guide.
5. **Missing / Excess Hardware.**
Recheck hardware count as per the part list.
6. **Product not installing properly.**
Ensure make model year, cab length and bed size of your vehicle is listed in the application. All installation steps are followed correctly.