



AUTOMOTIVE PRODUCTS, INC.

INSTALLATION INSTRUCTIONS

APPLICATION: E-SERIES, SIG. SERIES & PLATINUM OVAL STEP BAR / 2015 & UP FORD F-150
 APP PART #: 21-3920, 21-3925, 21-3930, 21-3935, 21-3940, 21-3945, 23-3920, 23-3925, 23-3930, 23-3935, 23-3940, 23-3945, 23-73930, 23-73940, 25-3930, 25-3935, 25-3940, 25-3945, 26-3930, 26-3940.

ITEM	QUANTITY	DESCRIPTION	TOOLS NEEDED
1	1	DRIVER SIDE STEP BAR ASSEMBLY	RATCHET
2	1	PASSENGER SIDE STEP BAR ASSEMBLY	UTILITY KNIFE
3	1	DRIVER SIDE FRONT MOUNTING BRACKET	3/4 SOCKET
4	1	PASSENGER SIDE FRONT MOUNTING BRACKET	13MM SOCKET
5	1	DRIVER SIDE REAR MOUNTING BRACKET	TORQUE WRENCH
6	1	PASSENGER SIDE REAR MOUNTING BRACKET	SOCKET EXTENS.
7	4	1/2" HEX HEAD SCREW (YELLOW ZINC)	
8	4	1/2" FLAT WASHER (YELLOW ZINC)	
9	4	1/2" SPLIT LOCK WASHER (YELLOW ZINC)	
10	12	M8 HEX NUT (YELLOW ZINC)	
11	12	M8 FLAT WASHER (YELLOW ZINC)	
12	12	M8 SPLIT LOCK WASHER (YELLOW ZINC)	
13	12	M8 SQUARE PLASTIC POLY RETAINER	

ANTI-SEIZE LUBRICANT MUST BE USED ON ALL STAINLESS STEEL FASTENERS TO PREVENT THREAD DAMAGE AND GALLING .

1. Remove contents from box, verify if all parts listed are present and undamaged. Carefully read and understand all instructions before attempting installation.
2. Locate factory welded bolts on the rocker panel, See Figure 1.
3. Thread M8 square plastic poly retainer onto factory bolts for driver side. Repeat for passenger side, see Figures 2 and 3. (Note: The plastic poly retainers are necessary to prevent reaction between supplied steel equipment and aluminum rocker panel.)
4. Loosely install driver side mounting brackets with supplied M8 hardware. Repeat for passenger side, see Figures 4 and 5. (Note: The regular cab rear brackets, Figures 8-10, are different from the super cab/super crew rear brackets. The regular cab rear brackets do not have a gusset.)
5. Loosely install step bar to driver side mounting brackets using supplied 1/2" hardware. Repeat for passenger side, see Figures 6 and 7.
6. Align and adjust as necessary then torque: M8 hardware to 15-18 ft-lbs., and 1/2" hardware to 50-55 ft-lbs.

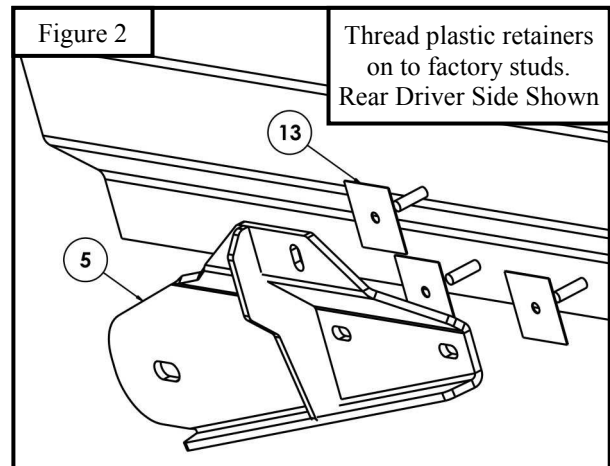
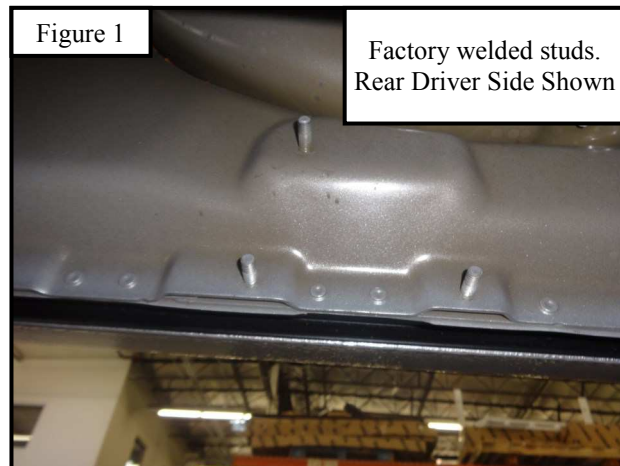

Westin Automotive Products, Inc.
 320W Covina Blvd
 San Dimas, Ca. 91773

Thank You for choosing Westin products
 For Additional installation assistance please call
 Customer service (800) 793-7846
www.westinautomotive.com

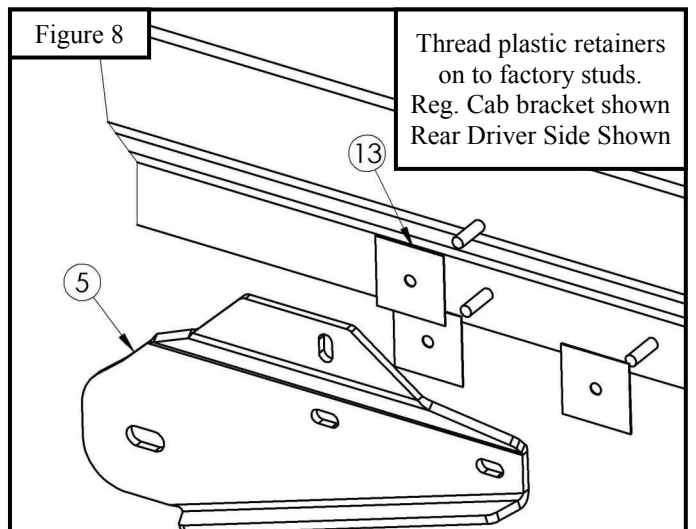
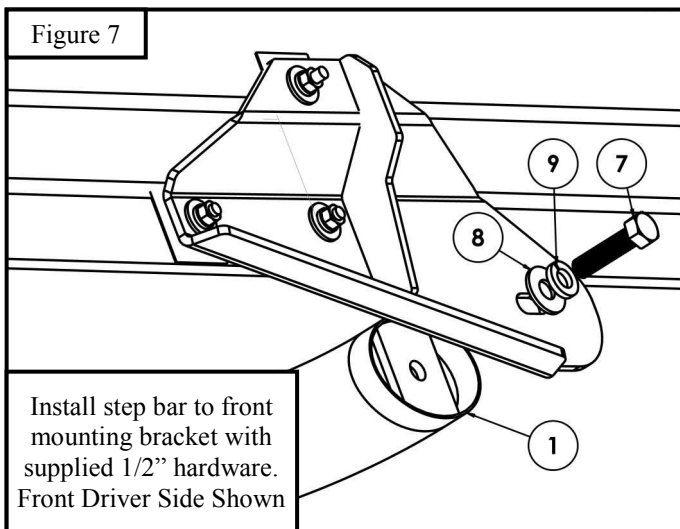
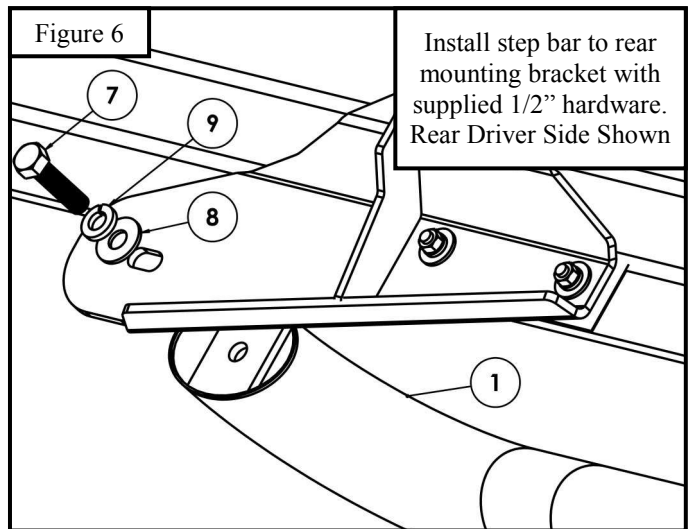
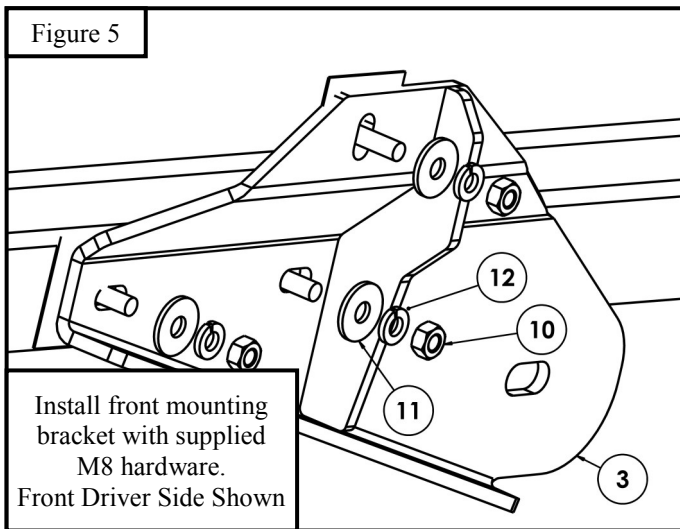
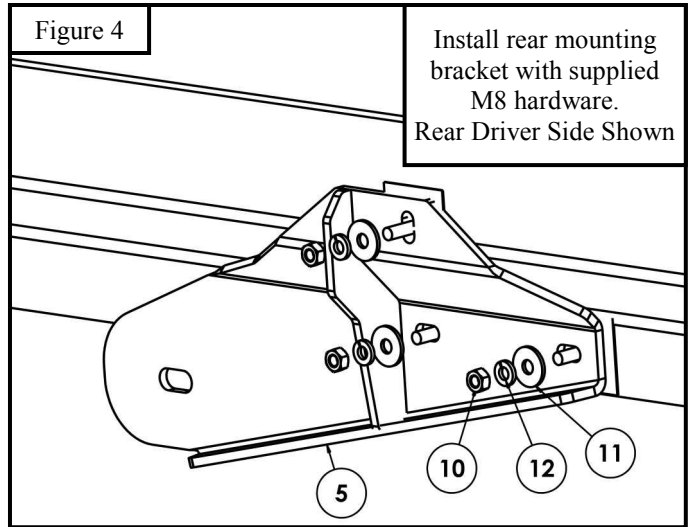
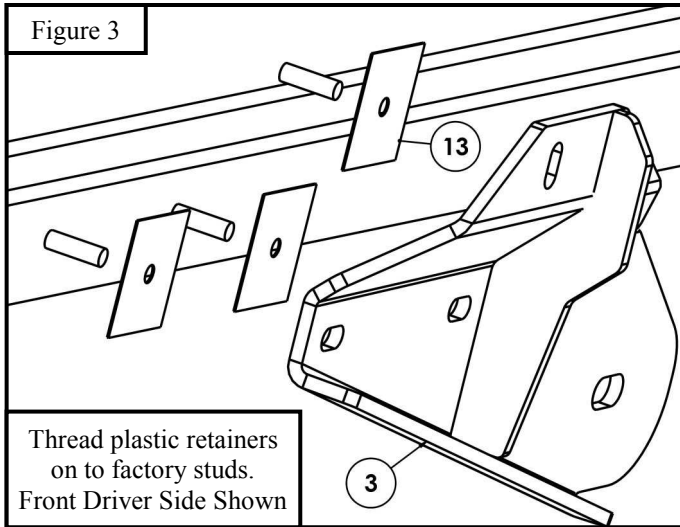

Westin Automotive Products, Inc.
320W Covina Blvd
San Dimas, Ca. 91773

Thank You for choosing Westin products
For Additional installation assistance please call
Customer service (800) 793-7846
www.westinautomotive.com

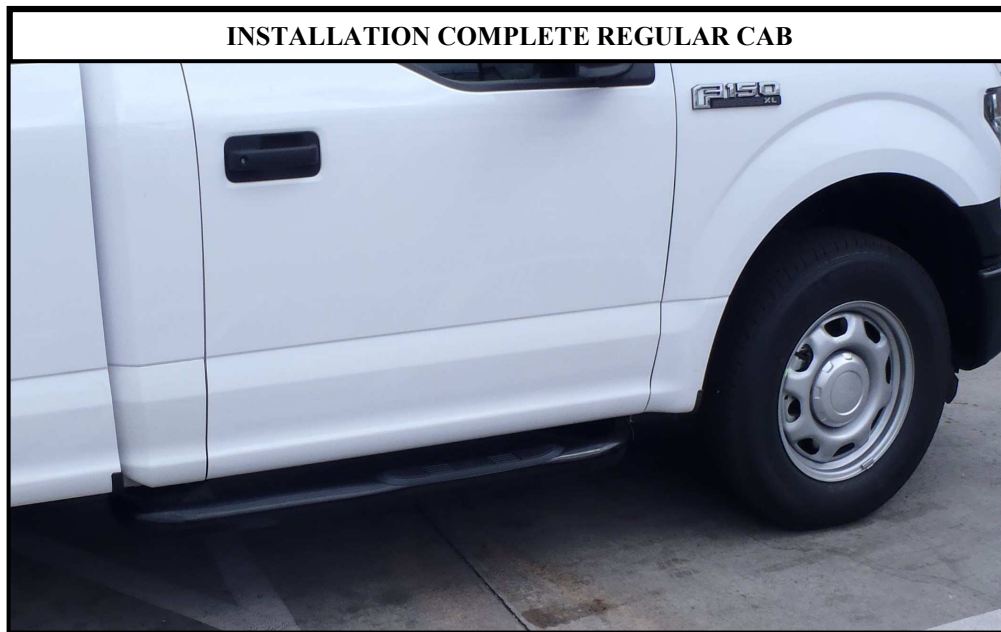
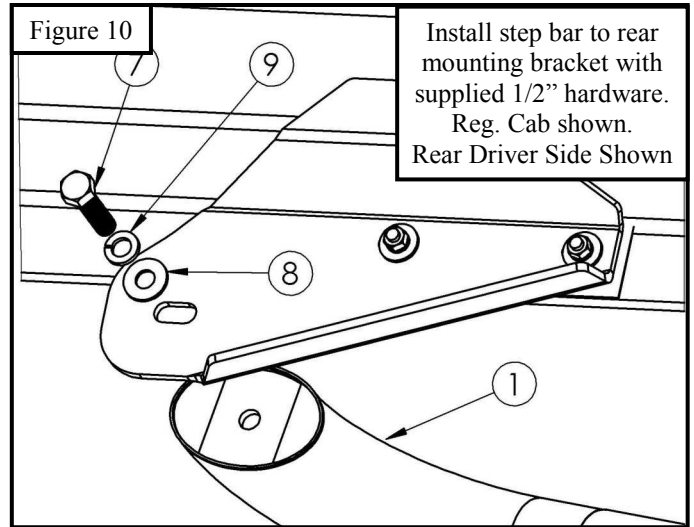
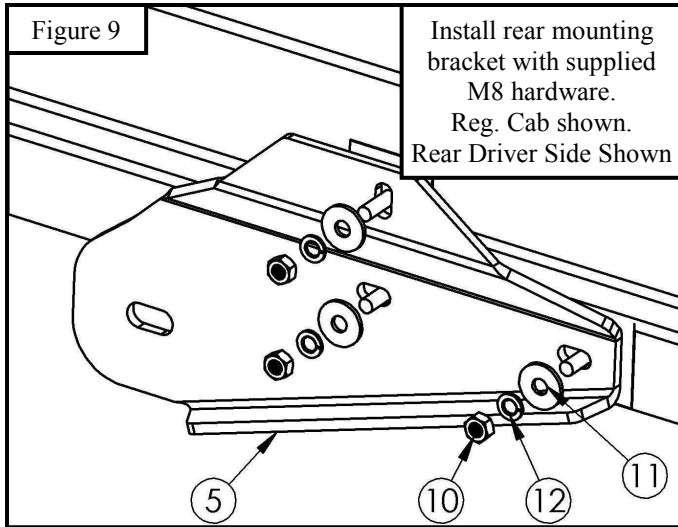

Westin Automotive Products, Inc.
320W Covina Blvd
San Dimas, Ca. 91773

Thank You for choosing Westin products
For Additional installation assistance please call
Customer service (800) 793-7846
www.westinautomotive.com

INSTALLATION COMPLETE SUPER CAB



INSTALLATION COMPLETE CREW CAB

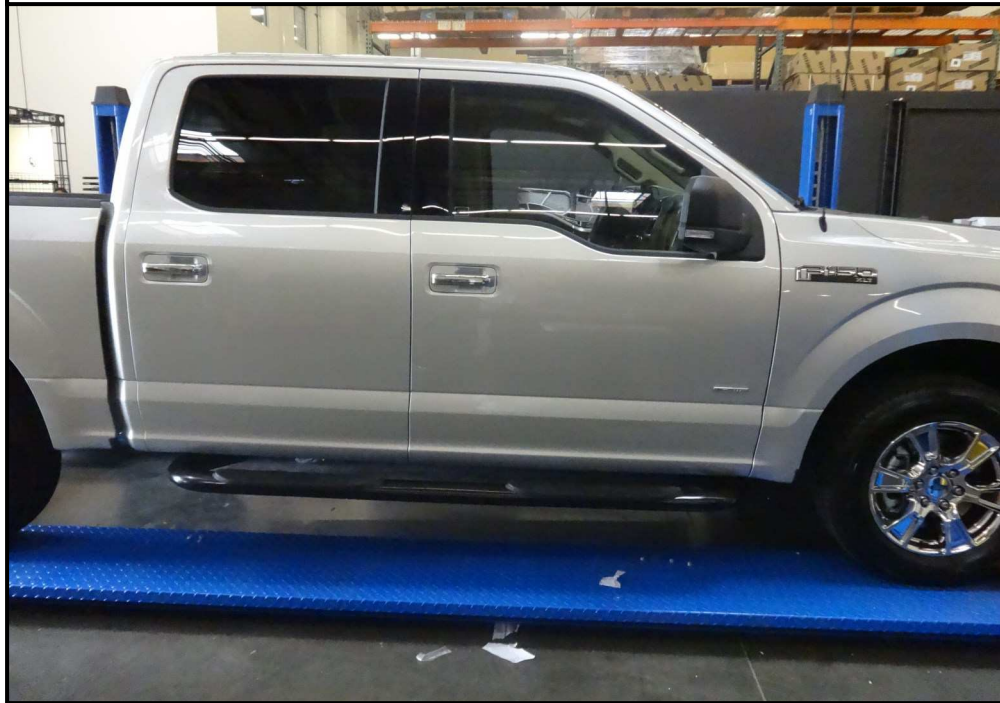

CARE INSTRUCTIONS

- REGULAR WAXING IS RECOMMENDED. DO NOT USE ANY TYPE OF POLISH OR WAX THAT MAY CONTAIN ABRASIVES.
- STAINLESS STEEL PRODUCTS CAN BE CLEANED WITH MILD SOAP AND WATER. STAINLESS STEEL POLISH SHOULD BE USED TO POLISH SMALL SCRATCHES.
- GLOSS BLACK FINISHES SHOULD BE CLEANED WITH MILD SOAP AND WATER.



Westin Automotive Products, Inc.
320W Covina Blvd
San Dimas, Ca. 91773

Thank You for choosing Westin products
For Additional installation assistance please call
Customer service (800) 793-7846
www.westinautomotive.com